

DENON

PROFESSIONAL MEDIA PLAYER & CONTROLLER

DN-HS5500

Owner's Manual

Bedienungsanleitung

Manuel de l'Utilisateur

Manuale delle istruzioni

Manual del usuario

Bruksanvisning

取扱説明書

操作说明书



CAUTION
RISK OF ELECTRIC SHOCK
DO NOT OPEN



CAUTION:

TO REDUCE THE RISK OF ELECTRIC SHOCK, DO NOT REMOVE COVER (OR BACK). NO USER-SERVICEABLE PARTS INSIDE. REFER SERVICING TO QUALIFIED SERVICE PERSONNEL.



The lightning flash with arrowhead symbol, within an equilateral triangle, is intended to alert the user to the presence of uninsulated "dangerous voltage" within the product's enclosure that may be of sufficient magnitude to constitute a risk of electric shock to persons.



The exclamation point within an equilateral triangle is intended to alert the user to the presence of important operating and maintenance (servicing) instructions in the literature accompanying the appliance.

IMPORTANT TO SAFETY

WARNING:

To reduce the risk of fire and electric shock, this apparatus should not be exposed to rain or moisture and objects filled with liquids, such as vases, should not be placed on this apparatus.

CAUTION:

1. Handle the power supply cord carefully

Do not damage or deform the power supply cord. If it is damaged or deformed, it may cause electric shock or malfunction when used. When removing from wall outlet, be sure to remove by holding the plug attachment and not by pulling the cord.

2. Do not open the rear cover

In order to prevent electric shock, do not open the top cover. If problems occur, contact your DENON DEALER.

3. Do not place anything inside

Do not place metal objects or spill liquid inside the system. Electric shock or malfunction may result.

Please, record and retain the Model name and serial number of your set shown on the rating label.

Model No. DN-HS5500

Serial No. _____

CAUTION:

USE OF CONTROLS OR ADJUSTMENTS OR PERFORMANCE OF PROCEDURES OTHER THAN THOSE SPECIFIED HEREIN MAY RESULT IN HAZARDOUS RADIATION EXPOSURE. THIS PRODUCT SHOULD NOT BE ADJUSTED OR REPAIRED BY ANYONE EXCEPT PROPERLY QUALIFIED SERVICE PERSONNEL.

This device complies with Part 15 of the FCC Rules. Operation is subject to the following two conditions: (1) This device may not cause harmful interference, and (2) this device must accept any interference received, including interference that may cause undesired operation.

This Class B digital apparatus meets all requirements of the Canadian Interference-Causing Equipment Regulations.

Cet appareil numérique de la classe B respecte toutes les exigences du Règlement sur le matériel brouilleur du Canada.

IMPORTANT SAFETY INSTRUCTIONS

READ BEFORE OPERATING EQUIPMENT

This product was designed and manufactured to meet strict quality and safety standards. There are, however, some installation and operation precautions which you should be particularly aware of.

1. Read these instructions.
2. Keep these instructions.
3. Heed all warnings.
4. Follow all instructions.
5. Do not use this apparatus near water.
6. Clean only with dry cloth.
7. Do not block any ventilation openings. Install in accordance with the manufacture's instructions.
8. Do not install near any heat sources such as radiators, heat registers, stoves, or other apparatus (including amplifiers) that produce heat.
9. Do not defeat the safety purpose of the polarized or grounding-type plug. A polarized plug has two blades with one wider than the other. A grounding type plug has two blades and a third grounding prong. The wide blade or the third prong are provided for your safety. If the provided plug does not fit into your outlet, consult an electrician for replacement of the obsolete outlet.
10. Protect the power cord from being walked on or pinched particularly at plugs, convenience receptacles, and the point where they exit from the apparatus.
11. Only use attachments/accessories specified by the manufacturer.
12. Use only with the cart, stand, tripod, bracket, or table specified by the manufacturer, or sold with the apparatus. When a cart is used, use caution when moving the cart/apparatus combination to avoid injury from tip-over.
13. Unplug this apparatus during lightning storms or when unused for long periods of time.
14. Refer all servicing to qualified service personnel. Servicing is required when the apparatus has been damaged in any way, such as power-supply cord or plug is damaged, liquid has been spilled or objects have fallen into the apparatus, the apparatus has been exposed to rain or moisture, does not operate normally, or has been dropped.



Additional Safety Information!

15.  Marked terminals are HAZARDOUS LIVE and that the external wiring connected to those terminal requires installation by an instructed person or the use of ready-made leads or cords.

TOP PANEL DIAGRAM / ÜBERSICHT AUF DER SCHALTAFEL OBEN /
 SCHEMA DU PANNEAU SUPERIEUR / ILLUSTRAZIONE PANNELLO
 SUPERIORE / DIAGRAMA DEL PANEL SUPERIOR / ÖVERSIKT ÖVER
 TOPPANELEN / トップパネル / 顶面板视图

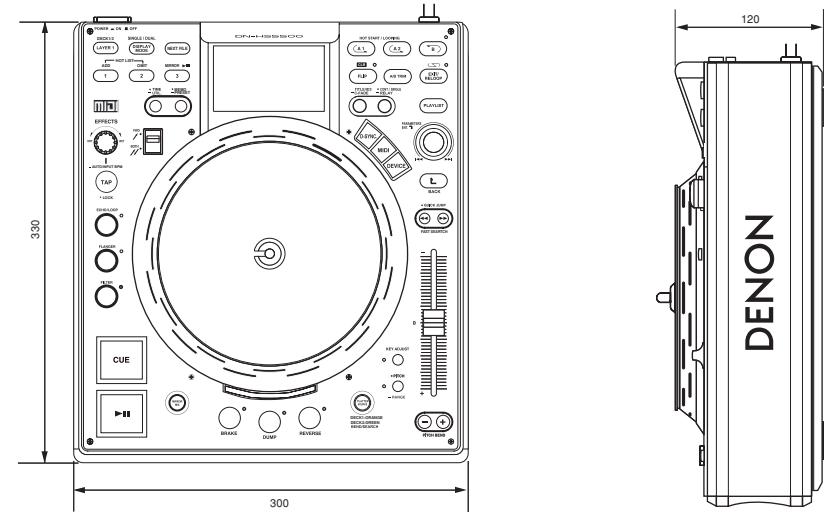
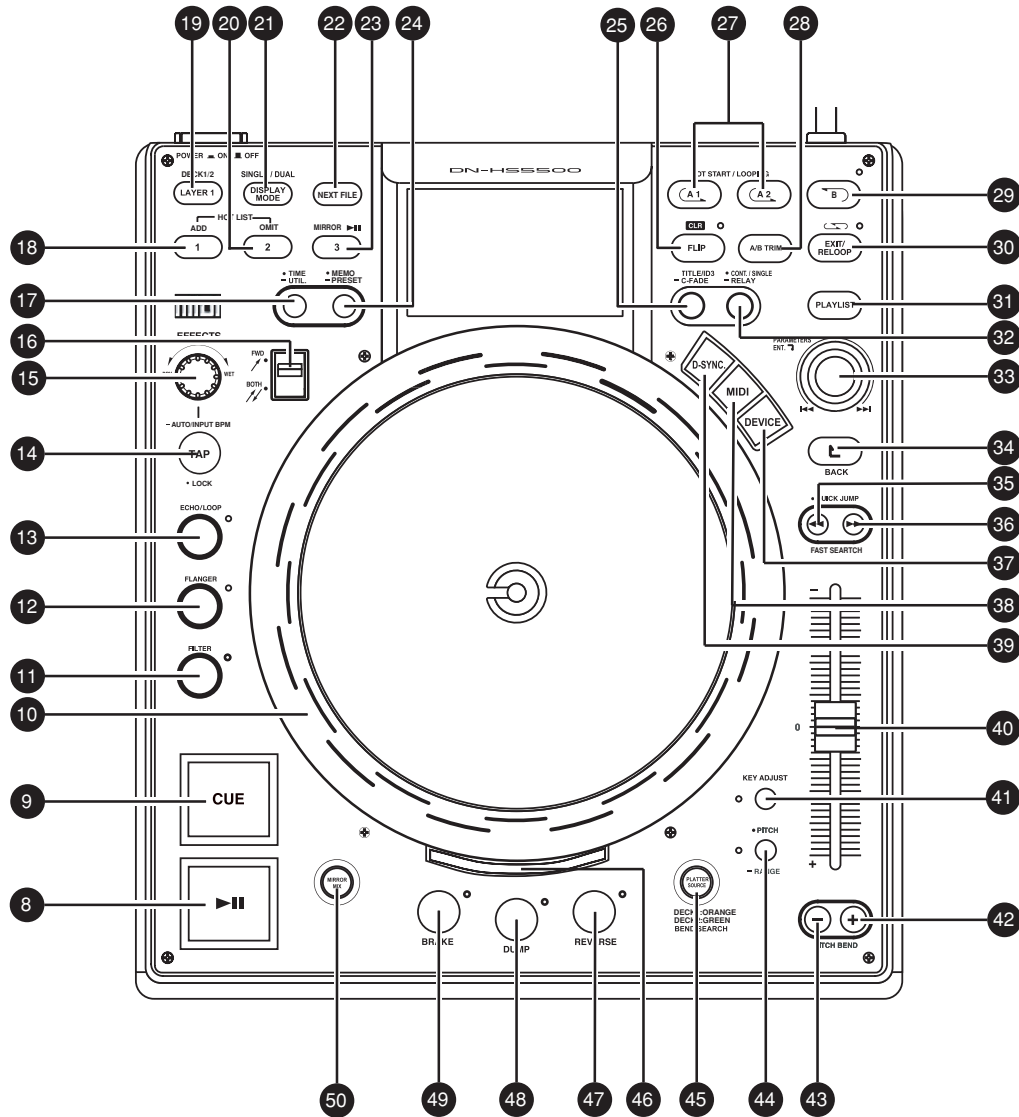



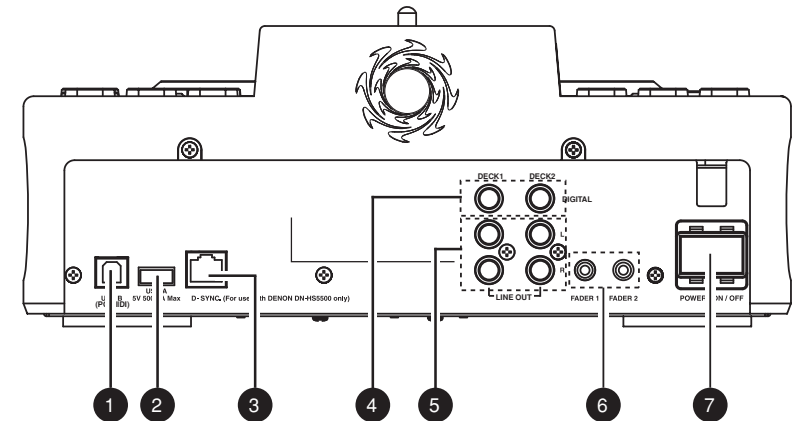



REAR PANEL DIAGRAM / HINTERES ANSCHLUSSFELD-SCHEMA /
 SCHEMA DU PANNEAU ARRIERE / SCHEMA PANNEAU ARRIERE /
 DIAGRAMA DEL PANEL POSTERIOR / BAKPANELEN / リアパネル /
 后面板视图

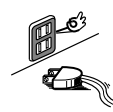
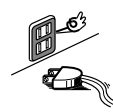

Unit: mm
 Gerät: mm
 Unità: mm
 Unità: mm
 Unidad: mm
 Einheit: mm
 単位: mm
 單位: mm

**NOTE ON USE / HINWEISE ZUM GEBRAUCH /
OBSERVATIONS RELATIVES A L'UTILISATION / NOTE SULL'USO /
NOTAS SOBRE EL USO / OBSERVERA**

 <ul style="list-style-type: none"> • Avoid high temperatures. Allow for sufficient heat dispersion when installed in a rack. • Vermeiden Sie hohe Temperaturen. Beachten Sie, daß eine ausreichende Luftzirkulation gewährleistet wird, wenn das Gerät auf ein Regal gestellt wird. • Eviter des températures élevées. Tenir compte d'une dispersion de chaleur suffisante lors de l'installation sur une étagère. • Evitate di esporre l'unità a temperature alte. Assicuratevi che ci sia un'adeguata dispersione del calore quando installate l'unità in un mobile per componenti audio. • Evite altas temperaturas. Permite la suficiente dispersión del calor cuando está instalado en la consola. • Undvik höga temperaturer. Se till att det finns möjlighet till god värmeavledning vid montering i ett rack. 	 <ul style="list-style-type: none"> • Keep the apparatus free from moisture, water, and dust. • Halten Sie das Gerät von Feuchtigkeit, Wasser und Staub fern. • Protéger l'appareil contre l'humidité, l'eau et lapoussière. • Tenete l'unità lontana dall'umidità, dall'acqua e dalla polvere. • Mantenga el equipo libre de humedad, agua y polvo. • Utsätt inte apparaten för fukt, vatten och damm. 	 <ul style="list-style-type: none"> • Do not let foreign objects in the set. • Keine fremden Gegenstände in das Gerät kommen lassen. • Ne pas laisser des objets étrangers dans l'appareil. • E' importante che nessun oggetto è inserito all'interno dell'unità. • No deje objetos extraños dentro del equipo. • Se till att främmande föremål inte tränger in i apparaten.
 <ul style="list-style-type: none"> • Unplug the power cord when not using the apparatus for long periods of time. • Wenn das Gerät eine längere Zeit nicht verwendet werden soll, trennen Sie das Netzkabel vom Netzstecker. • Débrancher le cordon d'alimentation lorsque l'appareil n'est pas utilisé pendant de longues périodes. • Disinnestate il filo di alimentazione quando avete l'intenzione di non usare il filo di alimentazione per un lungo periodo di tempo. • Desconecte el cordón de energía cuando no utilice el equipo por mucho tiempo. • Koppla ur nätkabeln om apparaten inte kommer att användas i lång tid. 		 <ul style="list-style-type: none"> • Do not let insecticides, benzene, and thinner come in contact with the set. • Lassen Sie das Gerät nicht mit Insektiziden, Benzin oder Verdünnungsmitteln in Berührung kommen. • Ne pas mettre en contact des insecticides, du benzène et un diluant avec l'appareil. • Assicuratevi che l'unità non venga in contatto con insetticidi, benzolo o solventi. • No permita el contacto de insecticidas, gasolina y diluyentes con el equipo. • Se till att inte insektsmedel på spraybruk, bensin och thinner kommer i kontakt med apparatens hölje.
 <ul style="list-style-type: none"> • Handle the power cord carefully. Hold the plug when unplugging the cord. • Gehen Sie vorsichtig mit dem Netzkabel um. Halten Sie das Kabel am Stecker, wenn Sie den Stecker herausziehen. • Manipuler le cordon d'alimentation avec précaution. Tenir la prise lors du débranchement du cordon. • Maneggiare il filo di alimentazione con cura. Agite per la spina quando scollegate il cavo dalla presa. • Maneje el cordón de energía con cuidado. Sostenga el enchufe cuando desconecte el cordón de energía. • Hantera nätkabeln varsamt. Håll i kabeln när den kopplas från el-uttaget. 	 <p>* (For apparatuses with ventilation holes)</p> <ul style="list-style-type: none"> • Do not obstruct the ventilation holes. • Die Belüftungsöffnungen dürfen nicht verdeckt werden. • Ne pas obstruer les trous d'aération. • Non coprite i fori di ventilazione. • No obstruya los orificios de ventilación. • Täpp inte till ventilationsöppningarna. 	 <ul style="list-style-type: none"> • Never disassemble or modify the apparatus in any way. • Versuchen Sie niemals das Gerät auseinander zu nehmen oder auf jegliche Art zu verändern. • Ne jamais démonter ou modifier l'appareil d'une manière ou d'une autre. • Non smontate mai, né modificate l'unità in nessun modo. • Nunca desarme o modifique el equipo de ninguna manera. • Ta inte isär apparaten och försök inte bygga om den.

CAUTION:

- The ventilation should not be impeded by covering the ventilation openings with items, such as newspapers, tablecloths, curtains, etc.
- No naked flame sources, such as lighted candles, should be placed on the apparatus.
- Attention should be drawn to the environmental aspects of battery disposal.
- Do not expose the set to dripping or splashing fluids.
- No objects filled with liquids, such as vases, shall be placed on the apparatus.

ACHTUNG:

- Die Belüftung sollte auf keinen Fall durch das Abdecken der Belüftungsöffnungen durch Gegenstände wie beispielsweise Zeitungen, Tischtücher, Vorhänge o. Ä. behindert werden.
- Auf dem Gerät sollten keinerlei direkten Feuerquellen wie beispielsweise angezündete Kerzen aufgestellt werden.
- Bitte beachten Sie bei der Entsorgung der Batterien die geltenden Umweltbestimmungen.
- Das Gerät sollte keinerlei Flüssigkeit, also keinem Tropfen oder Spritzen ausgesetzt werden.
- Auf dem Gerät sollten keinerlei mit Flüssigkeit gefüllten Behälter wie beispielsweise Vasen aufgestellt werden.

ATTENTION:

- La ventilation ne doit pas être gênée en recouvrant les ouvertures de la ventilation avec des objets tels que journaux, rideaux, tissus, etc.
- Aucune flamme nue, par exemple une bougie, ne doit être placée sur l'appareil.
- Veuillez à respecter l'environnement lorsque vous jetez les piles usagées.
- L'appareil ne doit pas être exposé à l'eau ou à l'humidité.
- Aucun objet contenant du liquide, par exemple un vase, ne doit être placé sur l'appareil.

PRECAUZIONI:

- Le aperture di ventilazione non devono essere ostruite coprendole con oggetti, quali giornali, tovaglie, tende e così via.
- Non posizionare sull'apparecchiatura fiamme libere, come ad esempio le candele accese.
- Prestare attenzione agli aspetti legati alla tutela dell'ambiente quando si smaltisce la batteria.
- L'apparecchiatura non deve essere esposta a gocciolii o spruzzi.
- Non posizionare sull'apparecchiatura nessun oggetto contenete liquidi, come ad esempio i vasi.

PRECAUCIÓN:

- La ventilación no debe quedar obstruida por hacerse cubierto las aperturas con objetos como periódicos, manteles, cortinas, etc.
- No debe colocarse sobre el aparato ninguna fuente inflamable sin protección, como velas encendidas.
- A la hora de deshacerse de las pilas, respete la normativa para el cuidado del medio ambiente.
- No se expondrá el aparato al goteo o salpicaduras cuando se utilice.
- No se colocarán sobre el aparato objetos llenos de líquido, como jarros.

OBSERVERA:

- Ventilaciónen bör inte förhindras genom att täcka för ventilationsöppningarna med föremål såsom tidningar, bordsdukar, gardiner osv.
- Inga blottade brandkällor, såsom tända ljus, bör placeras på apparaten.
- Tänk på miljöaspekterna när du bortskaffar batteri.
- Apparaten får inte utsättas för vätska.
- Inga objekt med vätskor, såsom vaser, får placeras på apparaten.

DECLARATION OF CONFORMITY

We declare under our sole responsibility that this product, to which this declaration relates, is in conformity with the following standards: EN60065, EN55013, EN55020, EN61000-3-2 and EN61000-3-3. Following the provisions of 73/23/EEC, 2004/108/EC and 93/68/EEC Directive.

ÜBEREINSTIMMUNGSERKLÄRUNG

Wir erklären unter unserer Verantwortung, daß dieses Produkt, auf das sich diese Erklärung bezieht, den folgenden Standards entspricht: EN60065, EN55013, EN55020, EN61000-3-2 und EN61000-3-3. Entspricht den Verordnungen der Direktive 73/23/EEC, 2004/108/EC und 93/68/EEC.

DECLARATION DE CONFORMITE

Nous déclarons sous notre seule responsabilité que l'appareil, auquel se réfère cette déclaration, est conforme aux standards suivants: EN60065, EN55013, EN55020, EN61000-3-2 et EN61000-3-3. D'après les dispositions de la Directive 73/23/EEC, 2004/108/EC et 93/68/EEC.

DICHIARAZIONE DI CONFORMITÀ

Dichiariamo con piena responsabilità che questo prodotto, al quale la nostra dichiarazione si riferisce, è conforme alle seguenti normative: EN60065, EN55013, EN55020, EN61000-3-2 e EN61000-3-3. In conformità con le condizioni delle direttive 73/23/EEC, 2004/108/EC e 93/68/EEC. QUESTO PRODOTTO E' CONFORME AL D.M. 28/08/95 N. 548

DECLARACIÓN DE CONFORMIDAD

Declaramos bajo nuestra exclusiva responsabilidad que este producto al que hace referencia esta declaración, está conforme con los siguientes estándares: EN60065, EN55013, EN55020, EN61000-3-2 y EN61000-3-3. Siguiendo las provisiones de las Directivas 73/23/EEC, 2004/108/EC y 93/68/EEC.

ÖVERENSSTÄMMELSESINTYG

Härmed intygas helt på eget ansvar att denna produkt, vilken detta intyg avser, uppfyller följande standarder: EN60065, EN55013, EN55020, EN61000-3-2 och EN61000-3-3. Enligt stadgarna i direktiv 73/23/EEC, 2004/108/EC och 93/68/EEC.

A NOTE ABOUT RECYCLING:

This product's packaging materials are recyclable and can be reused. Please dispose of any materials in accordance with the local recycling regulations.

When discarding the unit, comply with local rules or regulations.

Batteries should never be thrown away or incinerated but disposed of in accordance with the local regulations concerning chemical waste.

This product and the accessories packed together constitute the applicable product according to the WEEE directive except batteries.

**HINWEIS ZUM RECYCLING:**

Das Verpackungsmaterial dieses Produktes ist für zum Recyceln geeignet und kann wieder verwendet werden. Bitte entsorgen Sie alle Materialien entsprechend der örtlichen Recycling-Vorschriften.

Beachten Sie bei der Entsorgung des Gerätes die örtlichen Vorschriften und Bestimmungen.

Die Batterien dürfen nicht in den Hausmüll geworfen oder verbrannt werden; bitte geben Sie die Batterien gemäß örtlichen Bestimmungen an den Sammelstellen oder Sondermüllplätzen ab.

Dieses Produkt zusammen mit den Zubehörteilen ist das geltende Produkt der WEEE-Direktive, davon ausgenommen sind die Batterien.

UNE REMARQUE CONCERNANT LE RECYCLAGE:

Les matériaux d'emballage de ce produit sont recyclables et peuvent être réutilisés. Veuillez disposer de tout matériau conformément aux règlements de recyclage locaux.

Lorsque vous mettez cet appareil au rebut, respectez les lois ou réglementations locales.

Les piles ne doivent jamais être jetées ou incinérées, mais mises au rebut conformément aux règlements locaux concernant les déchets chimiques.

Ce produit et les accessoires emballés ensemble sont des produits conformes à la directive DEEE sauf pour les piles.

NOTA RELATIVA AL RICICLAGGIO:

I materiali di imballaggio di questo prodotto sono riutilizzabili e riciclabili. Smaltire i materiali conformemente alle normative locali sul riciclaggio.

Per smaltire l'unità, osservare la normativa in vigore nel luogo di utilizzo.

Non gettare le batterie, né incenerirle, ma smaltirle conformemente alla normativa locale sui rifiuti chimici.

Questo prodotto e gli accessori inclusi nell'imballaggio sono applicabili alla direttiva RAEE, ad eccezione delle batterie.

ACERCA DEL RECICLAJE:

Los materiales de embalaje de este producto son reciclables y se pueden volver a utilizar. Disponga de estos materiales siguiendo los reglamentos de reciclaje de su localidad.

Cuando se deshaga de la unidad, cumpla con las reglas o reglamentos locales.

Las pilas nunca deberán tirarse ni incinerarse. Deberá disponer de ellas siguiendo los reglamentos de su localidad relacionados con los desperdicios químicos.

Este producto junto con los accesorios empaquetados es el producto aplicable a la directiva RAEE excepto pilas.

EN KOMMENTAR OM ÅTERVINNING:

Produktens emballage är återvinningsbart och kan återanvändas. Kassera det enligt lokala återvinningsbestämmelser.

När du kasserar enheten ska du göra det i överensstämmelse med lokala regler och bestämmelser.

Batterier får absolut inte kastas i soporna eller brännas. Kassera dem enligt lokala bestämmelser för kemiskt avfall.

Denna apparat och de tillbehör som levereras med den är de som uppfyller gällande WEEE-direktiv, med undantag av batterierna.

CAUTION:

To completely disconnect this product from the mains, disconnect the plug from the wall socket outlet.

The mains plug is used to completely interrupt the power supply to the unit and must be within easy access by the user.

VORSICHT:

Um dieses Gerät vollständig von der Stromversorgung abzutrennen, trennen Sie bitte den Netzstecker von der Wandsteckdose ab.

Die Hauptstecker werden verwendet, um die Stromversorgung zum Gerät völlig zu unterbrechen; er muss für den Benutzer gut und einfach zu erreichen sein.

PRECAUTION:

Pour déconnecter complètement ce produit du courant secteur, débranchez la prise de la prise murale.

La prise secteur est utilisée pour couper complètement l'alimentation de l'appareil et l'utilisateur doit pouvoir y accéder facilement.

ATTENZIONE:

Per scollegare definitivamente questo prodotto dalla rete di alimentazione elettrica, togliere la spina dalla relativa presa.

La spina di rete viene utilizzata per interrompere completamente l'alimentazione all'unità e deve essere facilmente accessibile all'utente.

PRECAUCIÓN:

Para desconectar completamente este producto de la alimentación eléctrica, desconecte el enchufe del enchufe de la pared.

El enchufe de la alimentación se utiliza para interrumpir por completo el suministro de alimentación a la unidad y debe de encontrarse en un lugar al que el usuario tenga fácil acceso.

FÖRSIKTIGHETSMÅTT:

Koppla loss stickproppen från eluttaget för att helt skilja produkten från nätet.

Stickproppen används för att helt bryta strömförsörjningen till apparaten, och den måste vara lättillgänglig för användaren.

– TABLE OF CONTENTS –

1 Main features2	12 Auto BPM Counter/Effector19, 20
2 Installing the platter, the scratch disc and the slipmat ...3	13 Platter effect.....21
3 Connections/Installation4, 5	14 2 Decks in 122
4 Part names and functions6 ~ 9	15 Mirror mix.....23
5 Turning on the power9	16 D-SYNC function23, 24
6 Selecting files.....10 ~ 14	17 Memo (Custom setting memory).....25
7 Basic operation14, 15	18 About character input26
8 Next file16	19 Utility27 ~ 33
9 Scratch17	20 Preset34
10 Seamless loop/Hot start/Stutter17, 18	21 Compatible files.....35
11 A/B trim18	22 Specifications35

• ACCESSORIES

Check that the following parts are included in addition to the main unit:

① Owner's Manual.....1	③ Connection cords for signal output (RCA)2
② CD-ROM.....1	④ USB cable1

1 MAIN FEATURES

Features

• 2 Decks in 1

One of the most riveting features of the DN-HS5500 is its independent Dual Deck-like operation with separate audio outputs. Deck 1 & Deck 2 can be operated simultaneously by a simple flip of a button, offering twice the power & creativity in a single deck. Each Deck layer has full access to all the available features as well as your connected devices & music library.

• High Torque Direct Drive Motor & Spinning Platter Design

Denon's proprietary 12-pole Direct Drive brushless motor design is keeping the art of the 110-year old turntable alive & true to its native feel, delivering instant full rotation speed with a powerful 2.5" kg/cm of start-up torque within 0.5 seconds for true turntable reaction and response. DJs can perform freely as if they were using a genuine analog turntable. Platter rotation can be changed from 33 to 45 R.P.M. for comfort.

• Modular HDD/CD Option (world's first)

By this powerful and unique design, the DJ is now in full control over their internal hardware preference by choosing our optional (BU5501) Slim-type CD-ROM drive or a 2.5" laptop size *Hard Drive as the secured "internal" source playback. Imagine the incredible media advantages of having two players and both options readily available at your fingertips. Get ready for tomorrow's DJ technology today.

*PATA-type only

• External USB Device Support

Got a portable music collection stored on external USB media?

No problem the DN-HS5500 can support multiple external USB mass storage class devices direct or via a USB 2.0 hub (sold separately). Connect your, iPod®, Jump Drive, and large USB Hard Drives for easy access to your small or extensive mp3/wav libraries. Simply plug these devices into the DN-HS5500 to obtain the powerful on-board features such as, Instant Start, Seamless Looping, Scratching and File Searching, just to name a few.

*Up to 4 storage devices can be connected at once.

*Mass Storage Class iPods only

• MIDI Interface Controller (PC/MAC)

The DN-HS5500 is more than just player, it's also designed to interface & control a variety of popular DJ programs that supports USB MIDI in/out interface, either by user custom mapping or direct native support by the software vendor. Control you favorite software or your hard disk full of music all from one clever player, your complete backup solution has arrived.

*Supported Platforms: Mac OSX 10.4 or Higher, Windows XP SP2, Windows Vista?

• USB Audio Internal 24-Bit Processing &

Most DJ MIDI controllers on the market today don't include an internal sound card. The DN-HS5500 encompasses its own USB Audio interface (sound card) which eliminates the hassle to source one out and spend additional money. The internal power supply delivers optimum electrical specifications, resulting in best possible audio quality & performance, featuring industry leading Burr Brown (a product of TI) 24 bit DAC processing for superior output audio fidelity. USB Audio interface includes 2-Channel Stereo output pair, 44.1kHz sampling ranges and low latency ASIO / OSX Core Audio support.

• D-Sync.

Two DN-HS5500 players can be linked together by a single RJ45 cable for MASTER / REMOTE operation. This EASY operation enables the DJ to make all their peripheral connections to a single player while having full control of your music devices from either side.

• 5 Superb Built-in DSP Effects

Building the mood of your dance floor and remixing live has never been so easy with our on-board effects. Easily activate and have full parameter control with a unique Dry/Wet mix control of the effects: Flanger, Filter (High-Mid-Low), Echo, Tail Echo and amazing Echo Loop.

• 3 Platter Effects

- Brake (adjustable in real-time)
- Dump (reverse sound without losing true forward time, like a radio edit)
- Reverse (plays your music backwards and platter spins backwards too)

• Mirror Mix

The exclusive Mirror Mix feature is like having two copies of the same track while juggling the mixer's crossfader back and forth with the other track being slightly delayed. Delays setting are adjustable from, 1/2, 1/1, 2/1.

• Large 3.8" Display

This easy to follow bright display provides a visual text feedback of modes and parameters making it very intuitive for first time users to navigate without having to read the manual. The display options include split screen for simultaneous dual deck monitoring or larger single deck display mode.

• Pitch Range & Deep Pitch Resolution

For those DJ's who perform long mix transitions and require high pitch resolution, the DN-HS5500 offers .02 % for the 4 % pitch range and .05% for the 10/16% pitch range. 24%/50%/100% ranges are also available.

*Features 100 mm long stroke pitch slider for smooth mixing.

• Keyboard Support & Intuitive File Navigation System

The DN-HS5500 will support the 3-types of global USB keyboards (Qwerty, Qwertz, Azerty) in 9 different native languages for simplified song search of; Artist, Album, Title, Genre, Year, BPM, File Name, Hot List & Folder Structure.

In addition, shortcut keys are assigned to perform various functions and Latin-1 character searching is available.

• Playlist Creation & Hot List

The powerful on-board Playlist function allows you to create, edit and save up to 3 different types of Playlist categories, Top 40, Favorite, & Your Own Custom list. Hot List stores your immediate requests or songs you intend to play throughout the course of your gig. Once the file is played a check-mark appears next to it.

Key Adjust:

The Key Adjust feature keeps vocals and music sounding true even when you adjust the speed of the track.

• Hot Starts & Seamless Looping:

Two Hot Starts (A1 and A2) can be made on the fly and easily turned into Seamless Loops. The Hot Starts can also be used as Stutter points as well.

• Loop A/B Trim

The A or B point for the seamless loops can be easily adjusted on-the-fly to perfection.

• Memo function

Cue point, BPM, Pitch Setting & Range, Pitch ON/OFF, Key Adj ON/OFF, and Seamless Loop A and B data can be stored directly to the file for later recall.

• Next File Function w/Cross Fade

You can search for your next file by any criteria (without interrupting playback) and crossfade seamlessly to that file for a smooth non-stop segue upon your command. *Cross fade time is user adjustable

• File Import / Export

You can now easily transport files to & from the internal HDD (when installed) and other USB devices that are connected.

• Multi-Function Platter Modes

- Deck 1 / 2 Selectable for:
 - Scratching Effect
 - Pitch Bend
 - Frame Search

• 4-Way BPM Counter

- Auto Beat Detection
- Manual TAP
- Manual BPM Input
- Reads MP3/WAV BPM Metadata (if available)

• Directional Scratch Lever

This original Denon feature allows the DJs to scratch in two ways The traditional forward/back scrub sound and the ingenious Forward stroke to perform the same cuts as if you were using a mixer's crossfader.

• Relay Play

Unattended playback is possible between both decks or two players.

Great for the cocktail hour or during dinner time at banquet halls.

• 3-way Pitch Bend (Scratch Disc, Bend buttons or platter finger pressure)

• Quick Jump / Beat Jump

We made searching fast & easy. You can move around quickly within a track/file by precise user adjustable increment time steps using Quick Jump. Beat Jump will actually move through your file by BPM reference, 8-beats at a time.

• Two Way CUE Search System

Supports traditional Denon Cueing method and another popular style as well.

• Instant Start (0.02 sec.)

• Fader Start (compatible with all Denon Mixers)

• Digital Outputs

• Software Upgradeable by USB

From time to time we will make subtle improvements to current features or add new compelling ones based on valuable user feedback. These new Plug Ins are always free and made available via our www.denondj.com website.

2 INSTALLING THE PLATTER, THE SCRATCH DISC AND THE SLIPMAT

(1) INSTALLING THE PLATTER, THE SCRATCH DISC and THE SLIPMAT

• Accessories

① Aluminum Platter.....	1
② Scratch Disc.....	1
③ Slip Mat.....	1
④ Adaptor (1).....	1

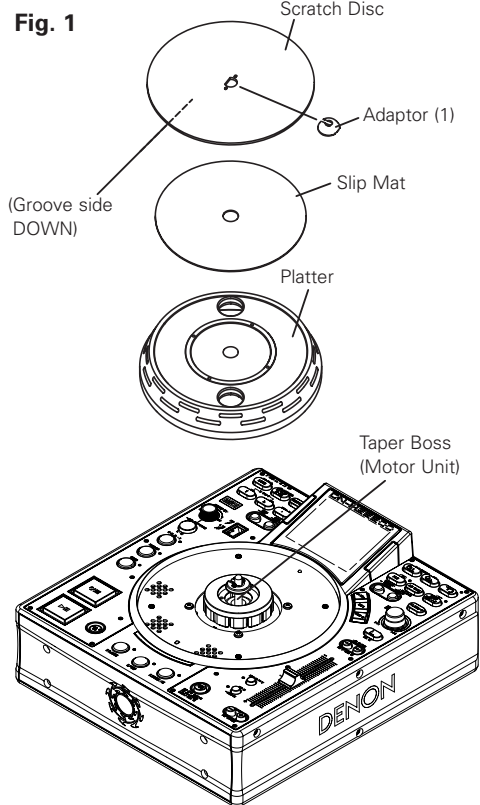

1. Install the Platter on the taper boss of the motor.
2. Install the Slip Mat on the Platter.
3. Insert D hole of the Scratch Disc on the D shaft of the Motor.
NOTE: The printed face is located on the Slip Mat side.
4. Insert the Adaptor according to the direction of the arrow.
NOTE: Please note the direction of insertion.

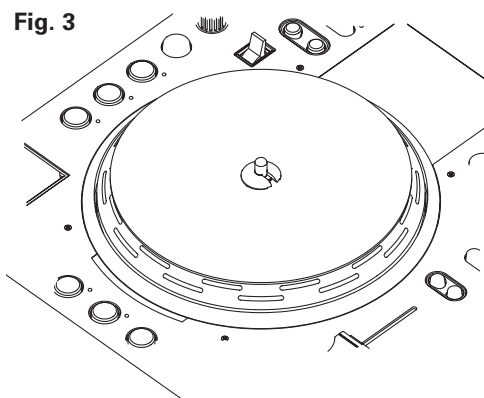
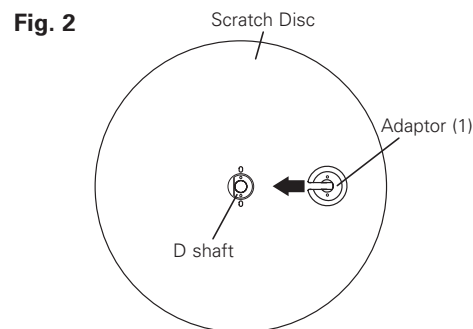

(2) INSTALLATION

Please set up DN-HS5500 horizontally.

(3) INSTALLING THE 7" RECORD ADAPTOR

Your own 7" vinyl record can be installed on this product by using the provided adaptor.

This original design grants you the freedom to use your favorite vinyl record for that ultimate analog turntable feel.

*Make sure the record used is flat and not warped.

• 7" record adaptor accessories

① Adaptor (2).....	1
② Screw (⊕ head).....	3
③ Fixing Plate.....	1

1. Set Adaptor (2) in the hole of 7" record.
2. Fix Plate with 3 screws. (⊕ head).
3. Insert D hole of the Adaptor (2) on the D shaft of the Motor.
4. Insert the Adaptor (1) on the Adaptor (2).

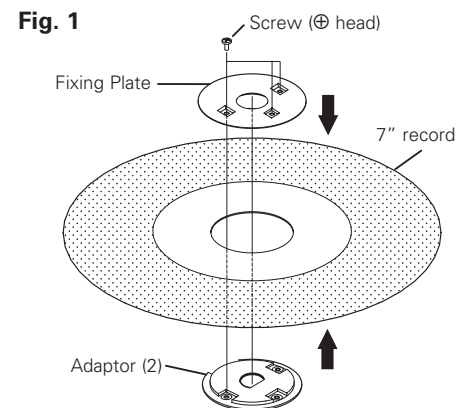
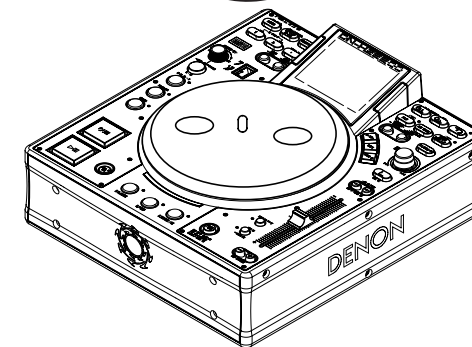
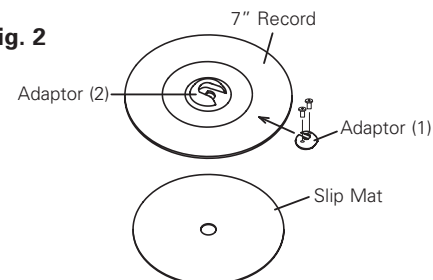

Fig. 2



NOTE:
Depending on the RECORD you choose, friction with the Slipmat may not be enough, which can cause an undesired drag sound.
If so, use a different record that's thicker or heavier.

CAUTIONS:

- Do not touch the motor unit.
- Do not turn on the power without the Platter being mounted.

NOTE:
Please note the position of Platter when you move DN-HS5500 after Platter is set.

3 CONNECTIONS/INSTALLATION

(1) CONNECTIONS

1. Turn off the POWER switch.
2. Connect the RCA pin cords to the inputs on your mixer.

CAUTION:

- Be sure to use the supplied control cord. Using another type of cable may result in damage.
- Be sure the power is off when connecting the control cord. Otherwise the units may not work properly.

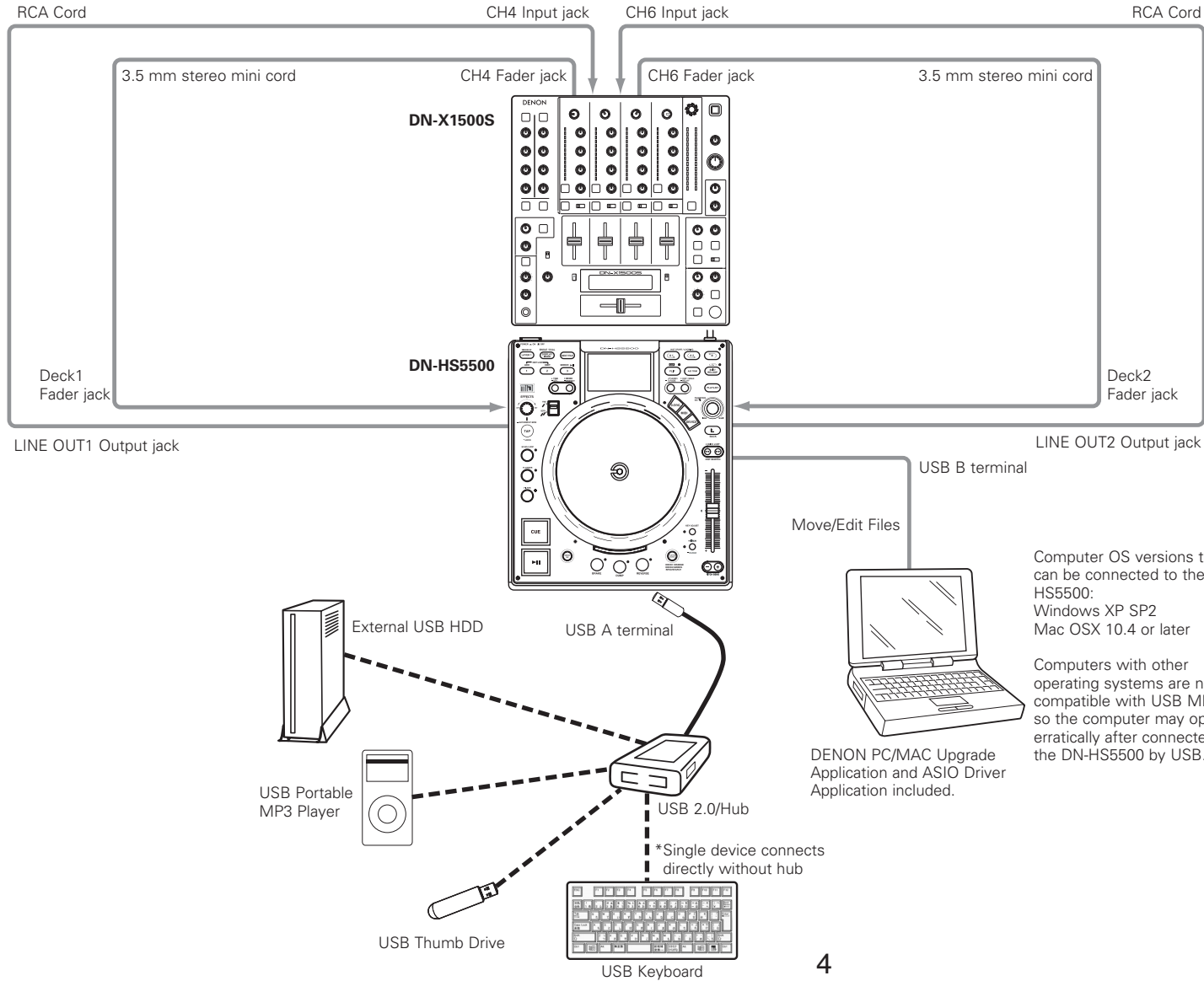

About connected devices

1. USB Hub

- ① Up to 4 mass storage devices and 1 keyboard can be connected.
- ② It is not possible to connect multiple USB hubs.
- ③ Be sure to use hi-speed compatible devices to ensure transfer performance.
(Products marked with the hi-speed USB logo recommended)
- ④ Bus power type USB hubs have a low power supply capacity, so the operation of the USB device connected to such hubs may be unstable. When using USB HDDs which require strong power or when using multiple USB devices, be sure to use a self-powered type USB hub.
- ⑤ When using a self-powered type USB hub, be sure to supply power to it when using it.
- ⑥ If a USB device connected to the USB hub is not recognized by the DN-HS5500, try disconnecting then reconnecting the device. If there are multiple devices connected to the hub, in some cases they will be recognized if the order in which they are connected is changed. It is best to connect one device at a time to check if it is recognized, then add more devices, checking each time.
- ⑦ Turn the power of the DN-HS5500 off when connecting the USB hub to it.

2. USB Keyboard

- ① Qwerty, Qwertz, Azerty type keyboard layouts are supported.
- ② Do not connect multiple units. Doing so will prevent proper operation.
- ③ The DN-HS5500 can be operated from the keyboard. For the usable keys and their functions, refer to the table right.

	Keyboard	DN-HS5500 Front Panel Button
1	↑	PARAMETERS knob (Scroll Up)
2	↓	PARAMETERS knob (Scroll Down)
3	Page Up	–
4	Page Down	–
5	ENTER	Pushing PARAMETERS knob
6	ESC	BACK button
7	TAB	Change Deck (Keyboard input)
8	TAB+Shift	When not in the D-SYNC mode, switches the machine that can be operated with the keyboard.
9	INSERT	SOURCE button
10	Windows	PLAY LIST button
11	ALT	NEXT FILE button
12	F1	TIME button
13	F2	TITLE/ID3 button
14	F3	CONT./SINGLE button
15	F10	Switches the quick jump setting.
16	F11	Inverts the LCD display.
17	F12	Switches the number of steps for file searching.

Previously it was only possible to switch the deck using the "Tab" key on the keyboard, but now in addition to the "Tab" key it is also possible to operate the PARAMETERS knob when searching to make keyboard input effective for the deck on the side to which the knob was operated.

NOTE:

- Keys (characters) other than the ones on the above table are used when inputting characters. For a list of the characters that can be used, see the section called "ABOUT CHARACTER INPUT".

3. All types of USB devices

- ① Operation of the USB device may be unstable when using the bus power only.
- ② Depending on the USB devices' specifications, some devices may not be identified, for example when using multiple devices.
- ③ If the USB device is not recognized, it might be recognized if it is disconnected then reconnected.
- ④ Devices on which power is supplied from the device to the host equipment side in a way not conforming to USB standards could damage the host equipment. Do not use such devices.
- ⑤ Do not disconnect a USB device when it is selected to be operated by the DN-HS5500 or when the database is being created. Disconnecting while the device is being accessed could damage files, etc.
- ⑥ For large capacity USB devices and USB devices that are not specifically designed for data storage (MP3 players, etc.), it may take some time for the device to be recognized after it is connected to the DN-HS5500.
- ⑦ Use devices in agreement with or conforming to compliance tests.

4. DENON DJ Music Manager

- ① Computer on which the Windows XP Service Pack 2 operating system is installed.
- ② HDD with enough free space for DENON DJ Music Manager to operate. (20 MB)
- ③ USB 2.0 connection terminal.

NOTE:

- When connecting the DN-HS5500 to a computer, do not use any software other than DENON DJ Music Manager.
The data on the HDD may be destroyed and the DN-HS5500 may be damaged if any software other than DENON DJ Music Manager is used.

5. iPod®

- ① Only Windows format iPods® can be used. Macintosh format iPods® cannot be used.
- ② MP3/WAV files transferred from iTunes® to an iPod® are read-only files, so the MEMO function cannot be used with them.
- ③ In iTunes®, place a check mark at "Manually manage music" in "Summary" – "Options".
- ④ MP3/WAV files transferred from iTunes® to an iPod® are managed with iPod's® specific file names, so it is not possible to search using the original file names. We recommend searching using ID3 tags (artist, album, title, genre, year, BPM, etc.).
* iPod® and iTunes® are trademarks or registered trademarks of Apple Computer, Inc.

6. Others

- ① With the DN-HS5500, the software can be updated using a USB device, but note that some time may be required for the device to be recognized.
- ② Do not use cables other than those conforming to USB standards. Using modified USB cables could damage the DN-HS5500.
- ③ If there is a large number of files stored in folders on the device, searching may take some time and operation may be unstable. Keep the number of files per folder to under 1000.

4 PART NAMES AND FUNCTIONS (Refer to page II.)

(1) Rear panel

1 USB B terminal

- Connect a computer.
- MP3/WAV files and playlist files are transferred between the computer and the DN-HS5500.

2 USB A terminal

- Connect a mass storage device, USB keyboard or USB hub.

3 D-SYNC terminals

- These are cable terminals for connecting another DN-HS5500.
- The D-SYNC function can be used when another DN-HS5500 is connected here.
- *Only a DN-HS5500 can be connected to the cable end.

4 Digital output terminals (DIGITAL OUT)

- Digital data is available from these terminals.
- Use 75 Ω/ohms pin cord for connection.
- We recommend you use braided wire type shielded cable.

NOTE:

- The playback level after analog conversion is set to -6 dB below the usual level to avoid digital distortion.

5 Analog output terminals (LINE OUT)

- This is unbalanced RCA output terminals.
- Audio signals outputs.

6 Fader start terminals

- Use this when your mixer has the Fader Start function.

7 POWER button (ON OFF)

- Push this button to turn power on and off.

(2) Top panel

CAUTION:

- Note that there are many buttons working two different function selected by short time pushing or long pushing (1second or more). The "●" mark indicates short time push function and "■" mark indicates long time push function.

8 PLAY/PAUSE button (▶||)

- This button will start or pause playback.
- Push once to start playback, once again to pause playback, and once more to resume playback.

9 CUE/STUTTER button

- Pushing this button in play mode will force the file back to the position which playback started. While in search mode, it makes new Cue point. (Cue)
- In Cue mode, by pushing the CUE button makes a Stutter sound from the Cue point. This is called Stutter play. (Stutter)

10 Platter/scratch disc

This is used for the manual search, pitch bend and scratch playback functions.

• Platter:

The platter turns when playback of the scratch source selected with the PLATTER SOURCE button starts.

NOTICE:

The platter does not turn when the scratch source is set to "BEND/SEARCH".

• Scratch:

When the scratch disc is turned, scratch playback of the source selected with the PLATTER SOURCE button is performed.

NOTE:

Do not forcibly stop the rotation of the platter as it is turning.

Doing so could damage the platter's rotation mechanism. Also, if the rotation of the platter is forcibly stopped, the pause mode will be set.

11 FILTER button

- One of three filters (LOW PASS, MID PASS and HIGH PASS) can be selected.

12 FLANGER button

- The depth and delay time can be selected.

13 ECHO/LOOP button

• ECHO LOOP:

The ECHO and LOOP functions can be selected. The feedback level and delay time can be selected. Looping for the delay time (ECHO LOOP) is possible by setting the feedback level to "MAX".

• Tail ECHO:

Echo playback is only performed when the file is stopped (play/cue operation).

The tail echo function is turned on and off by pressing the button and holding it in for 2 seconds.

14 TAP, ● LOCK, – AUTO/INPUT BPM button

• TAP:

When you push this button repeatedly, the Auto mode turns off and starts measuring your Beats Per Minute (BPM) by tapping.

• LOCK:

When this button is pressed once while the Auto BPM counter is operating, the data measured by the Auto BPM counter is locked.

• AUTO:

When pushing the TAP button for 1 second, activates AUTO BPM mode.

The measured BPM is displayed in the character section of the display.

• INPUT BPM:

When the TAP button is pressed and held in for more than 2 seconds, the BPM input mode is set and the BPM value can be input directly with the PARAMETERS knob. When the TAP button is pressed again, the BPM input mode is turned off.

NOTE:

- If you select a new file, AUTO BPM mode turns on automatically.
- BPM data can be saved to the MEMO function.

15 EFFECTS knob

- Use this knob to set the internal effector's parameters.

16 Scratch playback direction selector lever

Use this to select the direction of scratch playback.

• BOTH:

When the scratch disc is turned, the scratch playback sound is output from both the reverse and forward directions.

• FWD:

When the scratch disc is turned, the scratch playback sound is output from the forward direction only.

17 ● TIME, – UTIL. button

• TIME:

When this button is pressed, the time indicator switches between "ELAPSED" (elapsed time), "REMAIN" (remaining time), "T.ELAPSED" (total elapsed time) and "T.REMAIN" (total remaining time). (The "T.ELAPSED" and "T.REMAIN" indicators only light when in the playlist play mode.)

• UTIL.:

The Utility mode is set when this button is long-pressed while both Layers are in the cue.

18 Function1 button

Use this to register files on the hotlist.

- In the file search mode, the selected file is added to the hotlist.

19 LAYER1 button

Use this to select the deck to be operated.

- The LED on the left side of the LCD lights when Deck 1 can be operated.
- The LED on the right side of the LCD lights when Deck 2 can be operated.

20 Function2 button

Use this to mark files on the hotlist as already having played and to delete files from the hotlist.

- When the cursor is set to a file on the hotlist, that file is marked as already having played.
- When this is done, a check mark is added in front of the file name.

21 DISPLAY MODE button

- Use this to switch the display between the full and dual modes.

When the display is switched from the dual to the full mode, the display for the operable deck is displayed.

22 NEXT FILE button

If this button is pushed during playback, the NEXT FILE mode will be selected. The next file can be selected with the PARAMETERS knob.

23 Function3 button

- When in the mirror mix mode, this is used to start and stop the mirror mix operation.

24 ● MEMO, – PRESET button

• MEMO:

The MEMO mode starts when this button is pushed once in the Cue mode.

• PRESET:

When this button is pushed for more than 1 sec, the PRESET mode menu is displayed. The machine status must be in CUE, PAUSE or No JOG mode before entering the preset mode.

25 • TITLE/ID3, – C-FADE button**• TITLE/ID3:**

When an MP3/WAV file has ID3 Tag data, the artist name, album name, genre, BPM, and year are displayed.

• C-FADE:

Switches cross-fading on and off.

26 FLIP/CLR button**• FLIP:**

Use this to select operating mode of A1 and A2 buttons, from Hot Start mode and Stutter mode. The display will indicate "H/S" or "STR".

• A1, A2 CLR:

If the A1 or A2 button is pushed while pushing the FLIP button, you can clear the selected A point.

By holding down just the FLIP button for more than 1 sec, you can clear A1 and A2 points all at once.

27 A1, A2 button

• Using this button you can create starting point for Hot Start, Seamless Loop and Stutter.

28 A/B TRIM buttons

• When the button is pressed during playback, the *A/B TRIM MODE is selected. *Only when a seamless LOOP is set.

29 B button

• Use this to set the B point for to create a Seamless Loop after the A point has been set.

30 EXIT/RELOOP button

• Use this to exit or return back again to Seamless loop playback. You can add variety to looping with this function.

31 PLAY LIST button

Switches the playback mode.

• File Play:

Selects and plays an MP3/WAV file.

• Playlist Play:

Selects a playlist file and plays the MP3/WAV files registered on that playlist (up to 99 songs can be registered).

32 • CONT./SINGLE, – RELAY button**• CONT./SINGLE:**

A short tap of this button will toggle between 3 possible END modes for playback CONT. (continue: plays all files) SINGLE (stops playing and ReCUE's back to your original set point), PLAYLOCK-see below.

• SINGLE PLAY LOCK:

SINGLE PLAY LOCK can be selected by PRESET. When SINGLE PLAY LOCK is selected, file selection during playback is disabled. This prevents playback from stopping when the PARAMETERS knob is turned accidentally during playback. Play ending mode is the same as single.

• RELAY:

You can turn on and off RELAY PLAY mode.

33 PARAMETERS knob**• PARAMETERS:**

When the PARAMETER indicator is flashing, turn this knob to select and change the parameter for items found in the Platter effects, Memo, and Preset data, etc.

• FILE SEARCH:

When PARAMETER indicator is on, turn this knob to select files.

34 BACK button

• Press this button to return to the previous screen. A long-press shall return to the top menu.

**35 36 FAST SEARCH (▶▶) QUICK JUMP button
FAST SEARCH (◀◀), QUICK JUMP button****• QUICK JUMP:**

When one of these buttons is tapped shortly, the playback position jumps approximately 10 seconds in the reverse (◀◀) or forward (▶▶) direction. The jump time can be changed in the preset mode.

• FAST SEARCH:

When one of these buttons is pressed and held in, the disc is fast-searched in the reverse (◀◀) or forward (▶▶) direction.

37 DEVICE button

• Press this button to select the source (HDD, USB1 to 4).

38 MIDI button

• Use this to switch to the USB MIDI Control mode.

39 D-SYNC button

Use this to turn the D-SYNC mode on and off.

This function allows you to control the Deck 2 side of the other DN-HS5500 connected by cable.

(This is as if the unit for which the button is pressed becomes the controller.)

40 PITCH SLIDER

- Use this slider to adjust playing speed.
- The playing speed decreases when slid upwards and increases downwards.

41 KEY ADJUST button

- Use this to turn the key adjust mode on and off.

42 43 PITCH BEND ± buttons

- Pushing these buttons will change main playing speed temporarily.
- While pushing PITCH BEND + button the playing speed increases and speed decreases while pushing PITCH BEND – button.
- When release button, playing speed returns to the previous speed.

44 • PITCH, – RANGE button**• PITCH:**

The pitch mode turns on and off each time this button is pressed shortly and released.

The PITCH LED lights when the pitch mode is on.

• RANGE:

Push this button for more than 1 sec to select the pitch range. The pitch range can be selected with the PARAMETERS knob from ±4, 10, 16, 24, 50 or 100 %.

45 PLATTER SOURCE button

Select from Scratch playback, Bend mode, File search or Manual Frame Search mode.

• SCRATCH:

This button lights up or blinks in orange when scratching. Manipulate the sound by pushing down on the PLATTER disc.

• BEND/SEARCH:

When the PLATTER Source is set to BEND during playback, it alternates as the pitch bend function. The display will indicate "Bend". When PLATTER Source is set to Search, during Pause or CUE mode, it alternates as the Manual Search function. Manual search allows you to move the CUE point around by one frame at a time (1/75 second) with an audible frame-repeat sound. The display will indicate "Search".

46 Platter LED

This LED indicates the scratch memory and platter mode.

47 REVERSE button

- Push this button to set the REVERSE.

48 DUMP button

- Push this button to set the DUMP.

49 BRAKE button

- Push this button to set the BRAKE and adjust the parameter.

50 MIRROR MIX button

Press this button for over 1 second to turn the mirror mix mode on and off.

When in the mirror mix mode, if the button is pressed shortly and released, the mirror mix delay time can be selected with the PARAMETERS knob.

(3) Display

Dual display mode

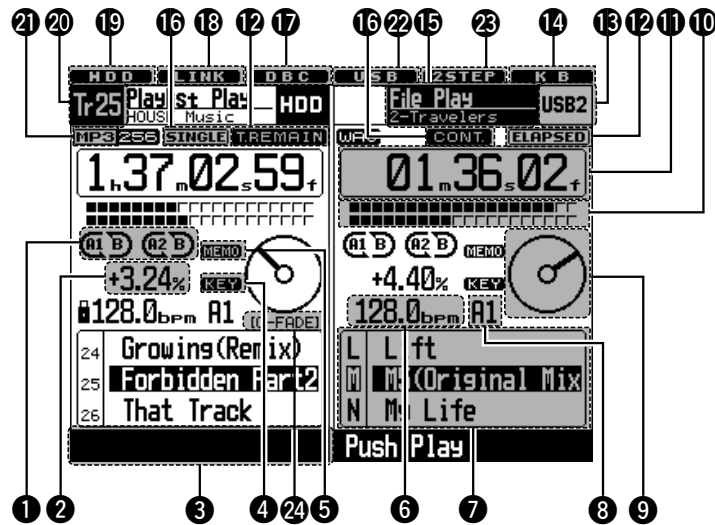

1 Loop mode indicators

- DN-HS5500 has Loop mode indicators which consist of A, B and two arrows. A and B marks indicate A and B points have been set.
- Two arrows indicate loop setting mode as follows.

(A1 B) or (A1 B) Left arrow only on:

Hot Start mode

(A1 B) Both arrows on:

Seamless Loop mode

(A1 B), (A1 B) Both arrows flashing:

Seamless Loop Playing

(A1 B), (A1 B) Left arrow on, right flashing:

Exit play from Seamless Loop

2 Pitch display

- This indicator display the playback speed (pitch).

3 Navigation display

- With the DN-HS5500, such operations as selecting the mode, etc., can be performed using the PARAMETERS knob following the instructions on the navigation display. The PARAMETER indicator flashes when it is possible to input using the PARAMETERS knob.

4 KEY ADJ. indicator

- KEY ADJ. indicator appears in display when the Key Adjust mode is ON.

5 MEMO indicator

- MEMO indicator appears in display when there is a memo setting found for the current playing File/Playlist or the File/Playlist at which the Cue standby mode is currently set.

6 BPM indicators

- Lights when the BPM is displayed on the pitch display.

7 Character display

- You can select the mode or function using PARAMETERS knob following the short message which is displayed on the character display area.
- The character display indicates the operation, mode name, data, etc., and displays such guide messages as "Push/Play" means if "YES", push PARAMETERS knob. The display indicates » and ↵ marks sometime, note that » mark says you to turn PARAMETERS knob and ↵ marks says to push PARAMETERS knob.
- The PARAMETER indicator flashes when you can use PARAMETERS knob, otherwise this knob used for File Selection.

8 BPM point display

- Displayed when the BPM value of the "A1" or "A2" point is being calculated.

9 Visual Marker

- This turns according to the playing status of the different decks.
- Use this as an indicator for scratching and other JOG operations.

10 Play Position indicators

- **Play position indicator:**
The 20 dots indicator a visual position marker during normal play. In the reverse play mode, the dots are inverted.
- **End of Message:**
When the file's end time is below the specified time, the lower section of the play position indicators flashes according to the file's remaining time (EOM), indicating the end of the file.
*The EOM time can be set in the presets.

11 Minute, second and frame displays

- These displays indicate current position information.

12 Time mode indicators

- When the TIME button is pushed, the Time mode indicator switches as follows:
ELAPSED:
File's elapsed time is displayed.
REMAIN:
File's remaining time is displayed.
T. ELAPSED:
The total elapsed time of Playlist is displayed.
T. REMAIN:
The total remaining time of Playlist is displayed.

13 Device display

- This displays the device currently selected for the different decks.

14 Keyboard connection indicator

- Deck for which keyboard is effective is now displayed.
(← K B)
Keyboard input effective for Deck 1
(K B →)
Keyboard input effective for Deck 2
(K B)
Keyboard input not dependent on deck (Utility Mode, etc.)

15 Mode display

- Upper section: Displays the current mode of the different decks.
- Lower section: Displays the current playlist name, artist name, etc., for the different decks.

16 Play mode indicators

- When SINGLE indicator lights up, playback will finish at end of current file.
- When CONT. indicator lights up, playback continues.

17 Database Creation indicator (DBC)

- This lights when a database is being created.

18 External device connection confirmation indicator (LINK)

- This flashes when an external device is connected. When flashing, press the SOURCE button to select the device. (The indicator does not flash when a keyboard is connected.)

19 HDD indicator (HDD)

- This lights when the HDD is being accessed.

20 Track indicator

- When in the playlist playback mode for the different decks, the track at which the play, pause or cue mode is set is displayed here. Nothing is displayed when in the file playback mode.

21 File data indicator

- This indicates the currently selected file format ("WAV" or "MP3") for the different decks. When the currently selected file format is "MP3", the bit rate, etc., is also displayed.

22 USB indicator

- This lights when a USB hard disc or USB thumb drive is being accessed.
*Do not disconnect the USB device while the indicator is lit.

23 2STEP indicator

- Displayed when the number of search steps for the file search mode is set to 2.

24 Cross Fader indicator

- This lights during crossfader playback.

Full display mode

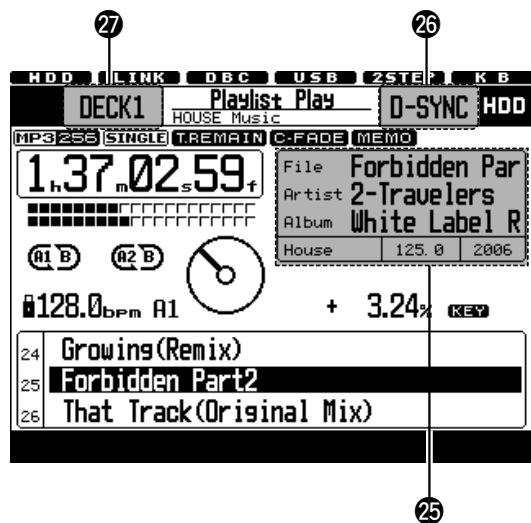
**25 Text display**

- The file name, artist name and album name for the file at which the cursor is set are displayed here.
- The title name is displayed in the text display section when the cursor is set to a file name, and the file name is displayed when the cursor is set to a title name.

26 D-SYNC mode indicator

- This is displayed when in the D-SYNC mode.
The D-SYNC indicator will only come on when two DN-HS5500 are connected together by a RJ45 cable.

27 Playing deck indicators

- These indicate the deck for which the panel buttons will operate.

5 TURNING ON THE POWER

- ① **Press the power button.**
The display below appears.



- Operation of the device set in the presettings starts.
 - If Power On Play is turned on, the playlist selected at "Power On Play" in the presettings is launched.
- ② **If the device selected above is not connected, select the device using the procedure shown below.**
 - Press the DEVICE button.
The device selection screen appears.
Turn the PARAMETERS knob or scratch disc to select the device.
Press the PARAMETERS knob to set the selected device.

6 SELECTING FILES

The DN-HS5500 offers two types of playback modes, as described below.

- **File Playback mode**

MP3/WAV files are searched for and selected by artist name, album name, genre, year, BPM, etc., and played in units of files.

- **Playlist Playback mode**

Playlists created and edited by the user are searched for and selected and the MP3/WAV files registered on that playlist are played. By using playlists, the DN-HS5500 can be operated with the same feel as conventional CDs.

Up to 1,000 playlists can be created per device. A maximum of 99 MP3/WAV files can be registered on each playlist.

The playback mode is switched using the PLAY LIST button. The mode switches between the file playback mode and playlist playback mode each time the PLAY LIST button is pressed. The playback mode can also be switched by pressing "Playlist Play" or "File Play" on the respective top menus. The playlist playback mode is set when the PLAY LIST button is lit.

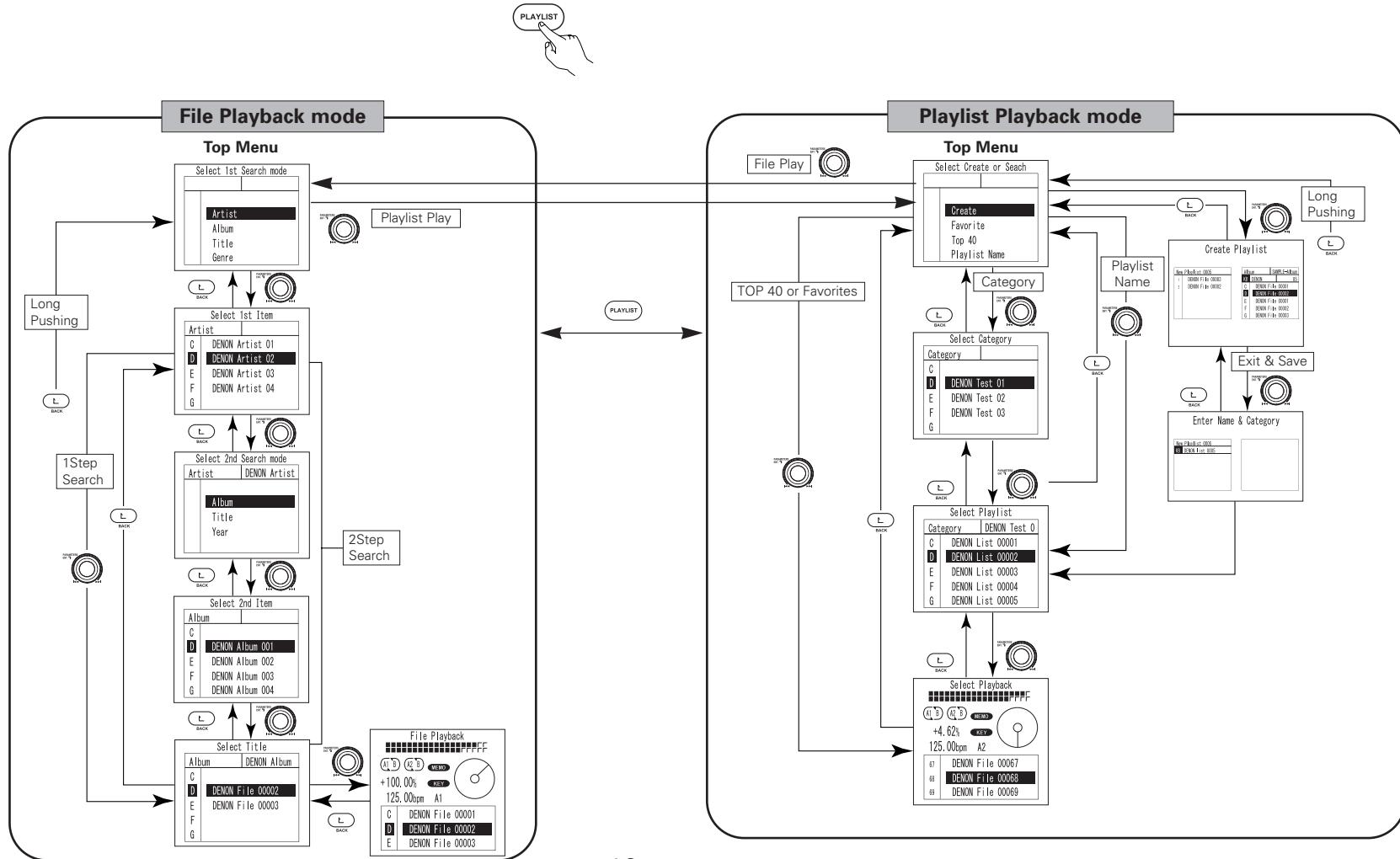

File Playback mode

In this mode you search for MP3/WAV files on the devices and select them for playback. One of the search modes below can be used. Two modes can be combined for greater precision.

Search modes

① 1Step Search (Factory Default)

Search mode
Artist
Album
Title
Genre
Year
BPM
File Name
Folder

② 2Step Search

1st Search mode	2nd Search mode
Artist	Album
	Title
	Year
	BPM
Album	–
	–
Genre	Artist
	Album
	Title
	Year
Year	Artist
	Album
	Title
	BPM
BPM	Artist
	Album
	Title
	Genre
File Name	–
Folder	–

For search modes (Album, Title, File Name and Folder) for which no 2nd search mode is indicated, the second search mode cannot be selected. Searching is done in the same way as for 1-step searching. 1-step or 2-step searching can be selected at "PRESET (17) Search Step". See "PRESET" on page 34. You may also temporarily change the step searching by pressing the F12 key when a keyboard is connected, from the top menu.

Searching procedure

The procedure for performing a file search from the top menu of the file playback mode is as described below.

To top menu

- When in the playlist playback mode: In the pause or standby mode, press the PLAY LIST button.
- When in the file playback mode: Either press the BACK button several times or long-press the BACK button.



1 At the top menu of the file playback mode, turn the PARAMETERS knob or scratch disc and select "Search mode".



Press the knob again to enter.

*Scratch disc can also be used for all searching steps.

Artist
Album
Title
Genre

2 (The following is the explanation for when "Artist" is selected at step 1.) A list of artist names appears on the display. Turn the PARAMETERS knob or scratch disc to select the desired artist name. Press the knob again to enter. For a 1-step search, proceed to step 5.



Artist
C DENON Artist 01
D DENON Artist 02
E DENON Artist 03
F DENON Artist 04
G

3 (The following is the explanation for when "Artist" is selected at step 1.) Turn the PARAMETERS knob or scratch disc to select the 2nd search mode (in this case, Album, Title, Year or BPM). Press the knob again to enter.



Artist	DENON Artist
Album	
Title	
Year	

4 (The following is the explanation for when "Album" is selected at step 3.) A list of album names for the artist selected in step 1 appears on the display. Turn the PARAMETERS knob or scratch disc to select the desired album name. Press the knob again to enter.



Album
C
D DENON Album 001
E DENON Album 002
F DENON Album 003
G DENON Album 004

5 A list of titles meeting the search criteria up to this point is displayed. Turn the PARAMETERS knob or scratch disc to select the title to be played. Press the knob again to enter.



Album	DENON Album
D	DENON File 00002
E	DENON File 00003
F	
G	

6 Once the title is set to CUE standby.

Folder Name Search

1 At the top menu in the file playback mode, turn the PARAMETERS knob or scratch disc to select "Search Mode". Press the PARAMETERS knob to set the selected search mode.



*The search mode cannot be set with the scratch disc.

File Name
Folder
Playlist Play

2 The folder name list is displayed. Turn the PARAMETERS knob or scratch disc to select the folder. Press the PARAMETERS knob to set the selected folder.



Folder
KB
Folder 01
Folder 02
Folder 03
Folder 04

3 A list of the files or folder names in the folder appears. Turn the PARAMETERS knob or platter disc to select the file to be played. Press the PARAMETERS knob to set the selected file. If a folder name is selected, a list of the files or folder names in the folder appears. Press the BACK button to move back up one folder.



Folder	Folder 01
KB	
Folder 01-01	
DENON FILE 01	
DENON FILE 02	
DENON FILE 03	
DENON FILE 04	

4 The cue standby mode is set.

■ Playlist Playback mode

In this mode you search for and select playlist files on the devices and play MP3/WAV files registered on that playlist. You can also create new playlists. Users can give playlists category names at their discretion and use these as search criteria.

*Playlists can also be created in the edit mode and using a computer management program (DENON DJ Music Manager).

Playlist Create

New playlists can be created from the top menu of the file playback mode. The procedure for doing so is described below.

To top menu

- When in the playlist playback mode: In the pause or standby mode, press the PLAY LIST button.
- When in the file playback mode: Either press the BACK button several times or long-press the BACK button.

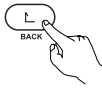

1 At the top menu of the file playback mode, turn the PARAMETERS knob or scratch disc and select "Create". Press the knob again to enter.

The set enters the mode for creating a new playlist.

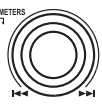

Top 40
Playlist Name
Category
File Play

2 Procedure for adding (adding a title to a playlist)

① A list of titles (empty at first) registered in the playlist is displayed on the left of the screen, the file search window is displayed on the right.

② When the title to be added to the playlist is entered at the file search window on the right side of the screen (Refer to "Searching procedure" on page 11), the entered title appears at the bottom of the list of registered titles on the left side.

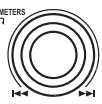

New Playlist 0005	
1	DENON File 00083
2	DENON File 00002

Album	SAMPLE-Album
KB DENON	85
C DENON File 00001	
D DENON File 00002	
E DENON File 00001	
F DENON File 00002	
G DENON File 00003	

3 Procedure for clearing (clearing titles from playlists)

At the file search window on the right side, turn the PARAMETERS knob or scratch disc and select "Clear" at the top of the list. Press the knob again to enter the selection. The title that was last added is cleared. The clearing procedure can be performed repeatedly.

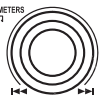

New Playlist 0005	
1	DENON File 00083

Album	SAMPLE-Album
KB	85
* Exit & Save	
Clear	
A DENON File 00001	
B DENON File 00002	
C DENON File 00003	

4 Procedure for exiting the clearing mode (saving the playlist)

① At the file search window on the right side, turn the PARAMETERS knob or scratch disc and select "Exit & Save" at the top of the list.

② Press the knob again to enter the selection. The window for entering the playlist name* appears on the left of the screen. Input the characters and enter them. (See "About character input" on page 26).

③ A window for entering the category name** appears on the left of the screen. Input the characters and enter them.

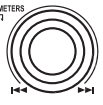

New Playlist 0005	
KB	DENON list 0005

5 The playlist you have created is added to the list of playlists.

***Playlist Name:**

The name of the file in which the various playlist information is stored, determined at the user's discretion.

****Category Name:**

Information used to categorize playlists. This information can be used when searching for playlists. Users can determine categories at their discretion, and can classify playlists according to the situation in which they are to be used (for example, "Wedding Party", "Karaoke Party", "Trance Rave", etc.).

Playlist Search

The procedure for searching for playlists from the top menu of the playlist playback mode is described below.



To top menu

- When in the file playback mode: In the pause or standby mode, press the PLAY LIST button.
- When in the playlist playback mode: Either press the BACK button several times or long-press the BACK button.

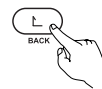

1 At the top menu of the playlist playback mode, turn the PARAMETERS knob or scratch disc and select "Playlist Name" or "Category". Press the knob again to enter.

If you have selected "Playlist Name", proceed to step 3. If you have selected "Category", proceed to step 2.

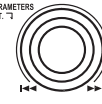

Top 40
Playlist Name
Category
File Play

2 The list of category names is displayed on the screen. Turn the PARAMETERS knob or scratch disc to select the category name. Press the knob again to enter.

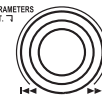

Category
C DENON Test 01
E DENON Test 02
F DENON Test 03
G

3 A list of playlists meeting the search criteria up to this point is displayed. Turn the PARAMETERS knob or scratch disc to select the playlist. Press the knob again to enter.

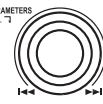

Category	DENON Test 0
C	DENON List 00001
D	DENON List 00002
E	DENON List 00003
F	DENON List 00004
G	DENON List 00005

4 A list of the titles on the select playlist is displayed. Turn the PARAMETERS knob or scratch disc to select the title to be played. Press the knob again to enter.

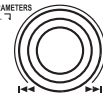

Press the knob again to enter.

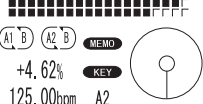

67	DENON File 00067
68	DENON File 00068
69	DENON File 00069

5 Once the title is set to CUE standby.

About "Top 40" and "Favorites"

These are preset playlists. Like other playlists, titles can be added and cleared from them at the user's discretion. These can be selected directly from the top menu of the playlist playback mode, allowing you to play your favorite titles without having to perform bothersome search operations. When edited, the settings are stored automatically, with no need to perform the operations for storing them as required with other playlists. A maximum of 40 songs can be registered at "Top 40", and up to 99 songs can be registered at "Favorites".

About the hotlist

- This is a function for temporarily storing files or tracks on the fly.
- The hotlist is cleared when the power is turned off.
- Hotlists can only be operated when a master device is connected.

1-1 Creating the hotlist

Use the PARAMETERS knob in the file search mode to select files to be added to the list.

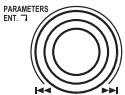

1-2

When the Function1 button is pressed, the file at which the cursor is set is added to the hotlist.

1

- * This does not apply to operations performed in the next file search mode.
- * If 99 files have already been added to the hotlist, a message saying that the new file cannot be added is displayed.

2-1 Playing the hotlist

Display the top menu in the playlist search mode. Use the PARAMETERS knob to select "Hotlist", then press the knob to set.

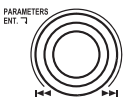

Playlist Name
Hotlist
Category
File Play

2-2

The files on the hotlist are displayed. Use the PARAMETERS knob to select the file to be played, then press the knob to set.

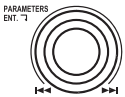

* Keyboard searching cannot be performed.

Hotlist	
C	DENON Hotlist 01
D	DENON Hotlist 02
E	DENON Hotlist 03
F	DENON Hotlist 04
G	

2-3

When the file is set, the playback screen appears and the cue standby mode is set. Press the PLAY/PAUSE (▶||) button to start playback.

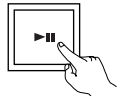

Marking files as already having played

Use this procedure to mark files that have not yet played as already having played. With the cursor set at the file on the hotlist, press the Function2 button to display the already played icon at that file.

22	√ DENON FILE 033
23	DENON FILE 067
24	DENON FILE 054

↓

22	√ DENON FILE 033
23	√ DENON FILE 067
24	DENON FILE 054

- * Normally the already played icon is displayed when the file is loaded and play enabled.
- * It is possible to play files for which the already played icon is displayed.

3

Deleting

Use this procedure to delete files from the hotlist. Select "Hotlist Edit" in the utility mode, then select "Delete List" or "Removed Played".

4

Delete List: To delete all the files from the hotlist.
Removed Played: To delete only files that have already played from the hotlist.

Device change

Searching is only performed within the currently selected device. To play a playlist or title on another device, or if you cannot find the desired playlist or title on the currently selected device, use the procedure described below to change the device.

1

Press the DEVICE button to display the "DEVICE" selection screen.



HDD	USB1	USB2	USB3	USB4	PC
-----	------	------	------	------	----

2

Turn the PARAMETERS knob or PLATTER disc to select the device. Press the knob again to enter.

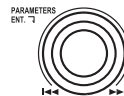

3

The top menu of the selected device is displayed with the playback mode maintained, so you can now search for the playlist or file. The USB device mode is set when "PC" is selected while a computer is connected.

USB MIDI Control Mode

1

The "USB MIDI Control Mode" starting confirmation screen is displayed when the MIDI button is pressed while a computer is connected.



2

Turn the PARAMETERS knob and select "OK". Press the PARAMETERS knob to enter.

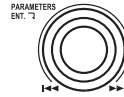

3

The USB MIDI control mode is started.



- * You can return to the initial startup screen by pressing the LAYER, NEXTFILE, A1 and B buttons for at least 4 seconds.

*USB Audio
The USB audio interface is compatible with two systems of stereo outputs and a sampling frequency of 44.1 kHz. Low latency ASIO/OSX Core. audio is supported.

Text search

Use this procedure to search for titles and albums in the file search or playlist search mode by first letter or by character strings. For example, to select the desired artist name from a list, you can press and turn the PARAMETERS knob and display only artist names beginning with a specific letter, number or symbol (in the order A, B, C ...). When you press and turn and select "E", only artists names starting with "E" are displayed. If a keyboard is connected, you can also display only artists names starting with letters, numbers or symbols input from the keyboard (maximum 8 characters).

Operating using the PARAMETERS knob

1

Press and turn the PARAMETERS knob or scratch disc at the screen for selecting the name of the artist, album, title, playlist, etc., and select the desired character from the left frame. Even if a character is input in the keyboard input section, when you press and turn the knob, the selected character (1 character only) is displayed.

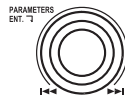

2

A list narrowed down to only the names starting with the character selected in step 1 is displayed.

*	All displayed
A ~ Z	Names starting with a letter from "A" ~ "Z"
#	Names starting with a number

3

Like with regular searching, turn the PARAMETERS knob or scratch disc to select a name from the list. Press the knob again to enter.

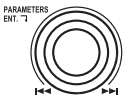

Operating from a keyboard

1	At the screen for selecting the name of the artist, album, title, playlist, etc., use the keyboard to input the desired letter, number or symbol (maximum 8 characters). (Refer to "About character input" on page 26.)
2	A list of only the names including the character (or character string) selected at step 1 is displayed.
3	Like with regular searching, turn the PARAMETERS knob or scratch disc to select a name from the list. Press the knob again to enter. 

If both the operation of pressing and turning the PARAMETERS knob and the operation of inputting from the keyboard are performed, the operation performed last is given priority.

7 BASIC OPERATION

Play and pause

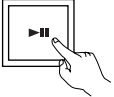
- Each push of the PLAY/PAUSE (▶||) button switches between playback and pause. PLAY/PAUSE (▶||) button illuminates solid green during playback and flashes in pause. 
- When the PLAY/PAUSE (▶||) button is pushed during play, the DN-HS5500 pauses playback at that point. Push PLAY/PAUSE (▶||) button once again and playback resumes.
- Playback will pause when SCRATCH is selected with the PLATTER SOURCE button and the scratch disc is held with your hand. Playback resumes when your hand is released.

Play and Cue

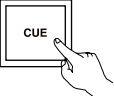
- When the CUE button is pushed during playback, the file stops and returns to the original position of which playback started from, the (Cue point). This function is also called Back-Cue. With the Back-Cue function, you can start from exactly same position. The CUE button illuminates solid red when DN-HS5500 is ready to start playback. 
- You can set and change Cue point as follows.
 - When you started playback.
 - File select finished.
 - Manual search.

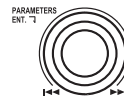

Select the file

- Turn the PARAMETERS knob or scratch disc.

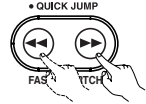
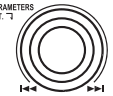

Move the Cue point

- If you would like to start playback other from the beginning of the file, you need to move Cue Point using fast Search, scan and manual search function.

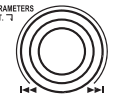
1-1	<p>You can move to the approximate playback start position by FAST SEARCH buttons. </p> <p>[QUICK JUMP]</p> <ul style="list-style-type: none"> • If the FAST SEARCH button is tapped shortly, the playback position jumps about 10 seconds. The jump time can be selected in the preset mode from 10, 20, 30 or 60 sec. • When "Beat" is selected for the "Quick Jump" preset item, operations 1-2 are performed. You may also temporarily change the search method from Quick Jump to Beat by pressing the F10 key when a keyboard is connected. <p>[FAST SEARCH]</p> <ul style="list-style-type: none"> • When the FAST SEARCH button is pressed and held in, the file/Track is fast-searched.
1-2	<p>Select the jumping width when "Beat" is selected for the "Quick Jump" preset item.</p> <ol style="list-style-type: none"> ① When the FAST SEARCH button is pressed, the jumping time is displayed on the LCD.  ② Use the PARAMETERS knob to adjust the jumping time. When the PARAMETERS knob is turned, the jumping width is entered and the set value is applied the next time the FAST SEARCH button is pressed.
2	<p>Push the PLATTER SOURCE button to set SCRATCH disc to search mode. The PLATTER SOURCE button will turn off. </p> <p></p>

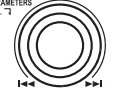
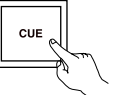
3	<p>Turn the PLATTER disc to change Cue point. You can hear the short sound of the current Cue point. When SCRATCH disc is turned in the pause, Cue or frame repeat mode, it works as the manual search function. </p>
4	<p>After you found your preferred Cue point, push the CUE button then a new Cue point is set. </p>

Adjusting the pitch

- With Pitch slider you can adjust the playback speed (Pitch).
- If you would not prefer to change key of sound, use the Key Adjust function.

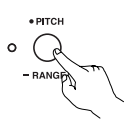
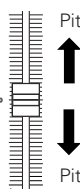
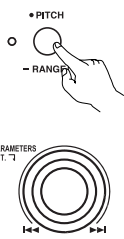
1	<p>Push the PITCH button to PITCH indicator lights up.</p> <ul style="list-style-type: none"> • PITCH ON ↔ OFF 	
2	<p>Pitch decreases</p> <p>↑ Move the Pitch Slider to adjust the pitch. The current pitch setting is displayed on the display.</p> <p>↓ Pitch increases</p>	
3	<p>DN-HS5500 has six pitch ranges, 4 %, 10 %, 16 %, 24 %, 50 % and 100%. When the RANGE button is pushed for more than 1 sec, the pitch range can be selected with the PARAMETERS knob.</p> <ul style="list-style-type: none"> • When the PARAMETERS knob is pushed the pitch range is entered and the pitch range selection mode is cancelled. 	
4	<p>Turning on the key adjust mode Press the KEY ADJUST button to turn the key adjust mode on. "KEY" lights.</p> <p>Turning the key adjust mode off Press the KEY ADJUST button to turn the key adjust mode off. "KEY" turns off.</p>	

Pitch Bend

- With PITCH BEND function you can change pitch temporary. DN-HS5500 has two ways for this function PITCH BEND buttons and PLATTER/SCRATCH disc.

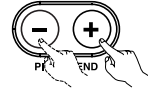
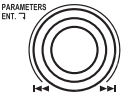
1	<p>[PITCH BEND +/- buttons]</p> <ul style="list-style-type: none"> • Push the PITCH BEND button for momentary change of pitch. • While holding these buttons down, the pitch continues to change up to the limitation. • After releasing the PITCH BEND buttons, playback pitch returns to slider setting. 	
2	<p>[PLATTER/SCRATCH disc]</p> <ul style="list-style-type: none"> • When the PLATTER SOURCE is set to SEARCH/BEND with the PLATTER SOURCE button, the playback speed can be changed by turning PLATTER/SCRATCH disc during playback. 	

Power On Play

- When "ON" is set at "[20] PRESET (23) Power On Play" and a playlist is set, playback starts from the first file on the set playlist when the power is turned on.

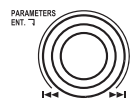
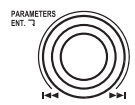
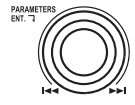
1	<p>In the standby or pause mode, press the Preset button for over 1 second to switch to the preset mode.</p>	
2	<p>Turn the PARAMETERS knob and select "Power On Play". Press the PARAMETERS knob to set.</p>	
3	<p>Turn the PARAMETERS knob and select "ON". Press the PARAMETERS knob to set.</p> <p>*If you leave the preset screen at this point, the playlist is not selected. In this case, the Power On Play function will not operate when the power is turned on.</p>	
4	<p>Turn the PARAMETERS knob and select the list from "Playlist" on the right side of the screen. Press the PARAMETERS knob to set.</p> <p>*If you leave the preset screen at this point without setting the playlist, the Power On Play function will not operate when the power is turned on.</p>	

Relay Playback

- Relay playback is a function for playing files on decks 1 and 2 of the DN-HS5500 continuously.

1	<p>Starting relay playback</p> <p>① Press the RELAY button for over 1 second to set the relay play mode. The relay play mode is set as described below.</p> <ul style="list-style-type: none"> • When relay play mode is set for either of the decks, both Deck 1 and Deck 2 are set to the relay play mode. • The "SINGLE" and "CONT." indicators flash when in the relay play mode. • When in the single play mode, once playback of the file on the currently playing deck is finished, playback starts on the other deck. • In the continuous play mode, once playback of all the files on the currently playing deck is finished, playback starts on the other deck. • Files/playlists on Deck 1 and Deck 2 can be played alternately. <p>*It is possible to overlap playback on decks 1 and 2. The time for overlapping can be set at "[20] PRESET (4) Next File CFade".</p>
2	<p>Stopping relay playback</p> <p>② In the relay play mode, press the RELAY button for over 1 second to turn the relay play mode off.</p>

8 NEXT FILE

- It's now possible to select the next file to be played while continuing playback of the current file without interrupting playback.

*Crossfade can also be used for a smooth transition.

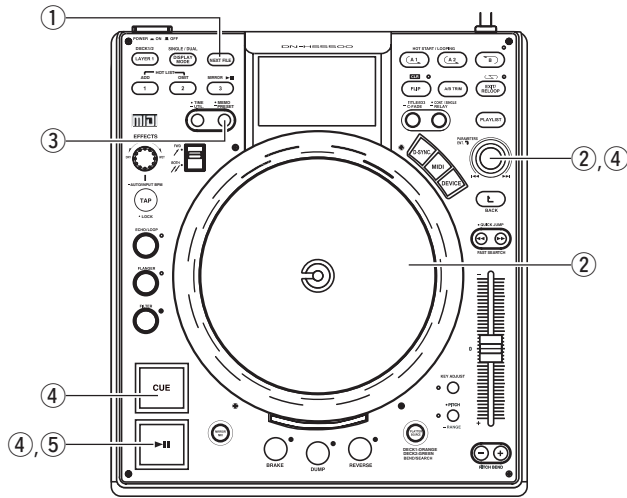

1	<p>Enter Next File mode</p> <p>① When the NEXT FILE button is pushed during playback, the NEXT FILE function is turned on.</p> <ul style="list-style-type: none"> • When this mode is set, CUE button blink. • When the button is pushed again, the NEXT FILE mode is turned off. • Only files stored on the same device can be selected with the NEXT FILE function.
	<p>Select the file</p> <p>② Turn the PARAMETERS knob or SCRATCH disc and select for the next file to be played.</p>



2-2	<p>Select the MEMO</p> <p>③ The CUE point of MEMO can be selected as NEXT FILE.</p> <ul style="list-style-type: none"> • When the NEXT FILE with which MEMO is memorized is selected, "MEMO" is displayed on the navigation display. • If the MEMO button is pushed at this time, the CUE point is memorized as the NEXT FILE & point to be selected. • The MEMO will be canceled if another file is selected by PARAMETERS knob or the MEMO button is pushed again.
------------	--

3	<p>File search start</p> <p>④ When the PARAMETERS knob or PLATTER disc or the CUE button is pushed after selecting the file, current playback continues as the next file is searched for and the standby mode is set. When the standby mode is set, the CUE button lights up and the PLAY/PAUSE button flashes.</p> <ul style="list-style-type: none"> • The time display indicates the remaining playback time for data in the memory after CUE is pressed. <p>NOTE: The amount of time for which playback of the currently continuing file can be continued is a maximum of 10 seconds from the time searching for the next file starts.</p>
4	<p>Next File playback start</p> <p>⑤ When the PLAY/PAUSE button is pushed, the current playback is stopped and playback of the next file starts.</p> <ul style="list-style-type: none"> *The currently playing file can be faded out when starting to play a different file. The fade out time can be selected at [20] PRESET "(4) Next File CFade". • If the PLAY/PAUSE button is not pushed after standing by at the next file, when in the CONT. playback mode, playback of the next file starts once all of the currently playing playback data has been played. The same goes for SINGLE playback mode.

9 SCRATCH

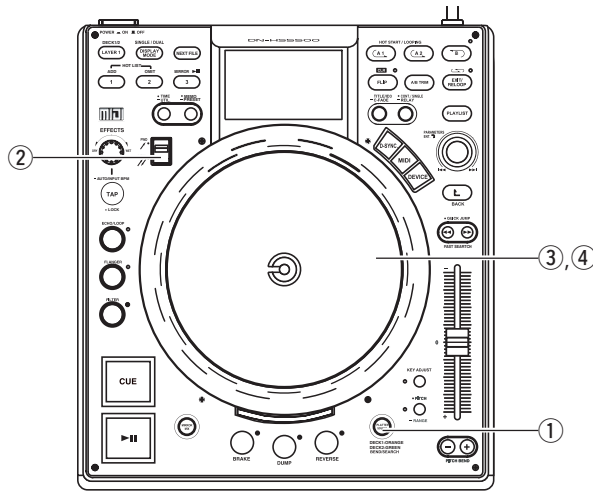
- Use this to select Deck 1 or Deck 2 and the direction of scratch playback (both directions or forward).

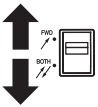



1	<p>Set the platter mode</p> <p>① Press the PLATTER SOURCE button and set the platter mode to scratch. The button lights orange when Deck 1 is selected. The button lights green when Deck 2 is selected.</p> 
2	<p>Select the direction for scratch playback</p> <p>② Use the scratch playback direction selection lever to select the direction for scratch playback.</p> 
3	<p>Starting scratch playback</p> <p>③ Turn the SCRATCH disc to perform scratch playback.</p> 
4	<p>Stopping scratch playback</p> <p>④ When the scratch disc is released, scratch playback stops and the play or pause mode is set.</p>

10 SEAMLESS LOOP/HOT START/STUTTER

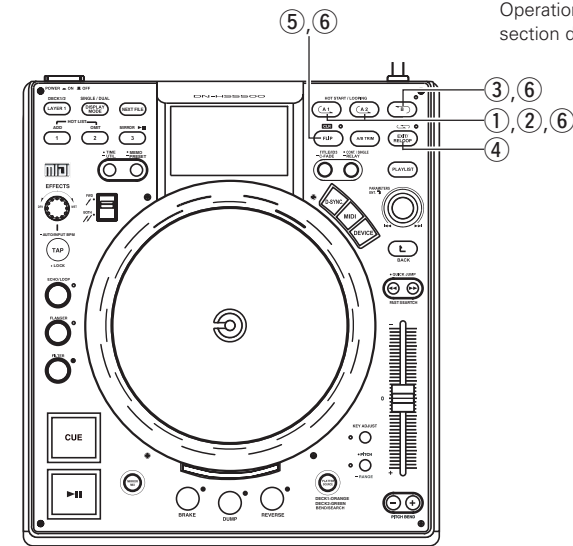
Seamless Loop/Hot Start/Stutter (A1, A2 buttons)



Operation display (refer to the section describing the display)

1	<p>Setting the A point (loading the Hot Start data)</p> <p>① Push the A1 or A2 button to set the A point and Hot Start data loading starts.</p> <ul style="list-style-type: none"> A1 and A2 buttons can be used separately for each Hot Start. When an A point is set, the corresponding A button and "A" display light and that button is set to the Hot Start mode. The BPM is set independently for each Hot Start automatically. 	3-1	<p>Setting the B point for Seamless Loop</p> <p>③ When the B button is pushed after setting the A point or after starting Hot start playback, the B point is set and Seamless Loop playback starts from the A point.</p> <ul style="list-style-type: none"> The B button works with respect to the A point operated before the B button was pushed. 
2	<p>Starts Hot Start</p> <p>② When A1 or A2 button is pushed, Hot Start playback starts from the corresponding A point.</p> 	3-2	<ul style="list-style-type: none"> If the B button is pushed during Seamless Loop playback or after EXIT playback, the B point moves to the point at which the button was pushed. When the B point is set, the "B" and "A" displays light.
4	<p>Playing Seamless Loops</p> <ul style="list-style-type: none"> When the B point for A1 is detected after playback started from A1 point, playback returns to A1 point with seamless. While A1 to B looping, B point for A2 ignored. When the B point for A2 is detected after playback started from A2 point, playback returns to A2 point with seamless. While A2 to B looping, B point for A1 ignored. 	4	

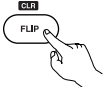
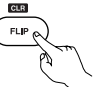
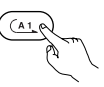

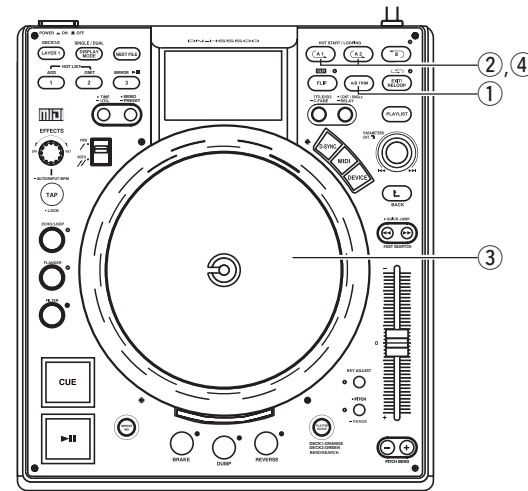

5	<p>Exit/Re loop</p> <p>④ In Seamless Loop playback, you can force exit from or return to the loop.</p>  <p>EXIT: While the Seamless Loop playback, push the EXIT/RELOOP button to exit from loop. DN-HS5500 continues playback after the B point.</p> <p>RELOOP: When the EXIT/RELOOP button is pushed after exit the loop, Seamless Loop playback resumes from the A point.</p>
6	<p>Stutter</p> <ul style="list-style-type: none"> A1 and A2 points can be also used for Stutter playback. <p>⑤ To enable stutter playback, push FLIP button for A1/A2 buttons, then "C" display turns off. Press the FLIP button to switch between the Hot Start/Seamless Loop and Stutter modes.</p> 
7	<p>Clear the A1/A2 point</p> <p>⑥ While pressing the FLIP/(CLR) button, push the A1 or A2 button to clear the corresponding A and B points. Or push the FLIP button for more than 1 sec to clear both A1 and A2 points at once. Quickly pressing the "FLIP" button first and then A1, A2 or B buttons will clear these points individually.</p>   <ul style="list-style-type: none"> If the device has been changed in the file playback mode or if the playlist has been changed in the playlist playback mode, the A1 and A2 points are cleared by force.

11 A/B TRIM

- The Seamless Loop A and B points can be fine-adjusted using the scratch disc.
- Trim the points during loop playback as a rehearsal.



A/B Trim

1	<p>① When the A/B TRIM button is pressed during seamless loop playback, the A/B TRIM mode is turned on.</p>  <p>To cancel A/B TRIM mode, press the A/B TRIM button again.</p>	<p>Save the A or B point</p> <p>④ Push the flashing A button again to save new A or B point, and the unit automatically exit from the A/B Trim mode.</p> 
2	<p>Select A or B point</p> <p>② Press the A1 or A2 button to select point A. Press the B button to select point B.</p>  <p>*The loop that can be adjusted is the currently playing loop.</p>	
3	<p>Trim A or B point</p> <p>③ Turn scratch disc slowly to move the A or B point 1 frame at a time.</p>  <ul style="list-style-type: none"> Range for trimming A or B point is limited as follows. <ul style="list-style-type: none"> ±30 frames of point A and up to 5 frames before point B B point for Loop: Between 5 frames after A point and file end. 	

12 AUTO BPM COUNTER/EFFECTOR

AUTO BPM COUNTER

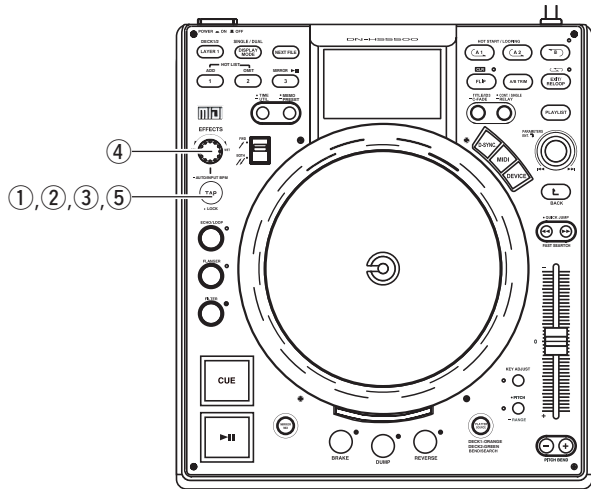

AUTO BPM COUNTER

- Beats per minute (BPM) of a file is measured automatically and displayed during playback or in Cue standby mode. Measured BPM values are synchronized with the effector parameters such as: (ECHO/LOOP and FLANGER time)
- When Auto BPM counter is off, pushing the TAP button for 1 second, reactivates the AUTO BPM COUNTER to turn back on.
 - If you change or select a new file, the old BPM is cleared and the Auto BPM counter starts to detect the new file automatically.

NOTE:

- AUTO BPM COUNTER might not be able to be measured correctly according to the music.
- *If this happens, please use the TAP or Manual In feature.

BPM LOCK

The data measured by the Auto BPM counter is locked.

- 1** ① Push the TAP button once while Auto BPM counter is operating. "BPM Lock" is displayed for 1 second.

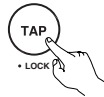

TAPPING

The interval when the TAP button is pushed repeatedly is measured and BPM is calculated accordingly.

- 2** ② When you push the TAP button, the Auto BPM counter turns off. Push the TAP button repeatedly about 5 ~ 10 times according to the beat.

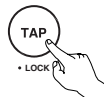

MANUAL INPUT

The known BPM can be dialed in directly by the numerical value.

- 3** ③ The BPM manual input mode is available when the TAP button is pushed for more than 2 sec. "Manual In" is displayed on the screen.



- 4** ④ You can input BPM value directly with the EFFECTS knob.

*When you push and turn the EFFECTS knob, you may also adjust the ".1" area.

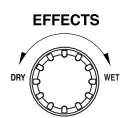

3

- ⑤ When the TAP button is pushed again, the BPM manual input mode is saved and the BPM is locked to that value.

NOTE:

- If the MP3 or WAV file contains metadata BPM information, this value is displayed as the default value and the LOCK icon will appear in the screen. You may override the default TAG by AUTO/TAP/MANUAL in as described above.

EFFECTOR

One of the four effects can be selected.

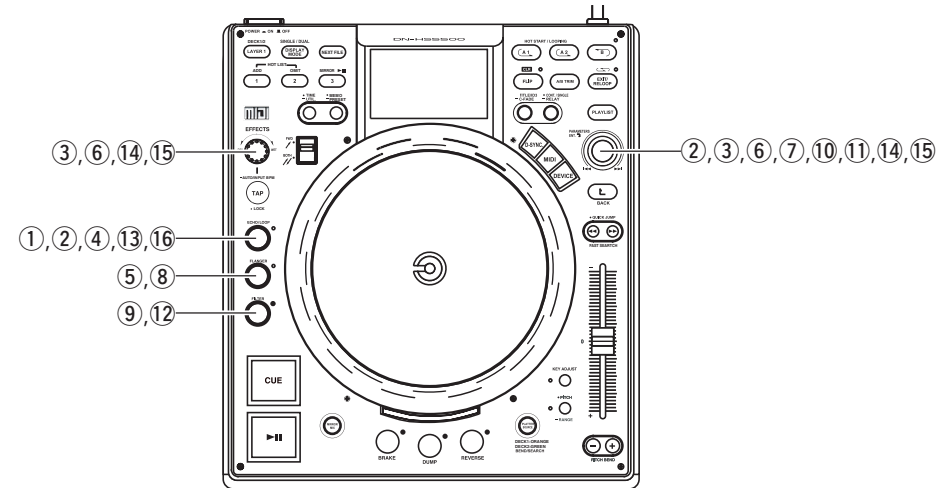

ECHO/LOOP

ECHO/LOOP ON

- 1-1** ① When the ECHO/LOOP button is pressed, the echo/loop function is turned on and the parameter selection mode is set.



*When echo/loop indicator is solid (not blinking), press the ECHO/LOOP button to set the parameter selection mode again.

Set the parameters

- 1-2** ② In the parameter selection mode, the "ECHO/LOOP" and "PARAMETERS" indicator flashes and the echo/loop parameters can be selected with PARAMETERS knob and EFFECTS Knob.





Echo Feedback level : EFFECTS knob
Echo Delay time : PARAMETERS knob

Select the LOOP mode

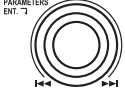

When the feedback level is set to the maximum, loop playback with the specified time begins. File can be search for and the file/Playlist can be replaced during loop playback by pressing the Cue button at this point.

ECHO LOOP FADE OUT

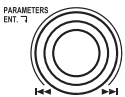

- 1-3**
- The parameter mode is turned off while the echo loop is reproducing when the back cue or NEXT FILE is selected at the parameter selection mode.
 - When the new track is selected and playback is started, echo loop playback stops by fade out. An echo loop playback and a normal playback can be smoothly replaced.

1-4	<p>Parameter selection mode OFF</p> <p>③ When the PARAMETERS knob is pushed, parameter selection mode is canceled.</p> 
1-5	<p>ECHO/LOOP OFF</p> <p>④ When the ECHO/LOOP button is pressed, the echo/loop parameter selection mode is set. If the ECHO/LOOP button is pressed again, the echo/loop function is turned off.</p> 

FLANGER

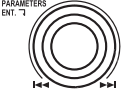
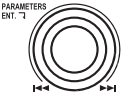

2-1	<p>FLANGER ON</p> <p>⑤ When the FLANGER button is pressed, the flanger function is turned on and the parameter selection mode is set.</p> <p>*When the flanger indicator is solid (not blinking), press the FLANGER button to set the flanger parameter selection mode again.</p> 
2-2	<p>Set the parameters</p> <p>⑥ In the parameter selection mode, the "FLANGER" and "PARAMETERS" indicator flashes and the flanger parameters can be selected with PARAMETERS knob and EFFECTS Knob.</p> <p>FLANGER Depth: EFFECTS Knob FLANGER Delay time: PARAMETERS knob</p> 
2-3	<p>Parameter selection mode OFF</p> <p>⑦ When the PARAMETERS knob is pushed, parameter selection mode is canceled.</p> 
2-4	<p>FLANGER OFF</p> <p>⑧ When the FLANGER button is pressed, the flanger parameter selection mode is set. If the FLANGER button is pressed again, the flanger function is turned off.</p> 

FILTER

3-1	<p>FILTER ON</p> <p>⑨ When the FILTER button is pressed, the filter function is turned on and the parameter selection mode is set.</p> <p>*When filter indicator is solid (not blinking), press the FILTER button to set the filter parameter selection mode again.</p> 
3-2	<p>Select the parameters</p> <p>⑩ In the parameter selection mode, the "FILTER" and "PARAMETERS" indicator flashes and the filter parameters can be selected with PARAMETERS knob and EFFECTS Knob.</p> <p>Filter Band width: EFFECTS Knob Filter types: PARAMETERS knob</p> 
3-3	<p>Parameter selection mode OFF</p> <p>⑪ When the PARAMETERS knob is pushed, parameter selection mode is canceled.</p> 
3-4	<p>FILTER OFF</p> <p>⑫ When the FILTER button is pressed, the filter parameter selection mode is set. If the FILTER button is pressed again, the filter function is turned off.</p> 

Tail Echo

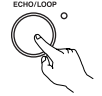
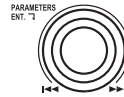
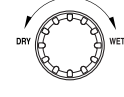
• Echo playback is only performed when the currently playing track is paused by the PLAY/PAUSE (▶||) button.

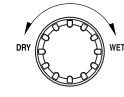
4-1	<p>Turning the tail echo mode on</p> <p>⑬ Press and hold in the ECHO/LOOP button for 2 seconds. The tail echo mode is turned on and the parameter selection mode is set.</p> <p>* If the tail echo mode is already on, the parameter selection mode is set when the ECHO/LOOP button is pressed.</p> 
4-2	<p>Setting the parameters</p> <p>⑭ When in the parameter selection mode, the ECHO/LOOP LED flashes and the echo/loop parameters can be set using the PARAMETER and EFFECTS knobs.</p> <p>Echo Feedback level: EFFECTS knob Echo Delay time: PARAMETERS knob</p>  
4-3	<p>Performing the tail echo operation</p> <p>When the tail echo mode is on, press the PLAY/PAUSE (▶) button during playback to perform the tail echo operation. When the PLAY/PAUSE (▶) button is pressed again during the tail echo operation, the tail echo operation is canceled and normal playback resumes.</p>
4-4	<p>Turning the parameter selection mode off</p> <p>⑮ Press either the PARAMETER knob or the EFFECTS knob to cancel the parameter selection mode.</p>  

4-5	<p>Turning the tail echo mode off</p> <p>⑯ When the ECHO/LOOP button is pressed, the tail echo parameter selection mode is set. The tail echo mode turns off when the ECHO/LOOP button is pressed again at this time. The tail echo mode can also be turned off by pressing the ECHO/LOOP button and holding it in for 2 seconds while the tail echo mode is on.</p> 
------------	---

13 PLATTER EFFECT

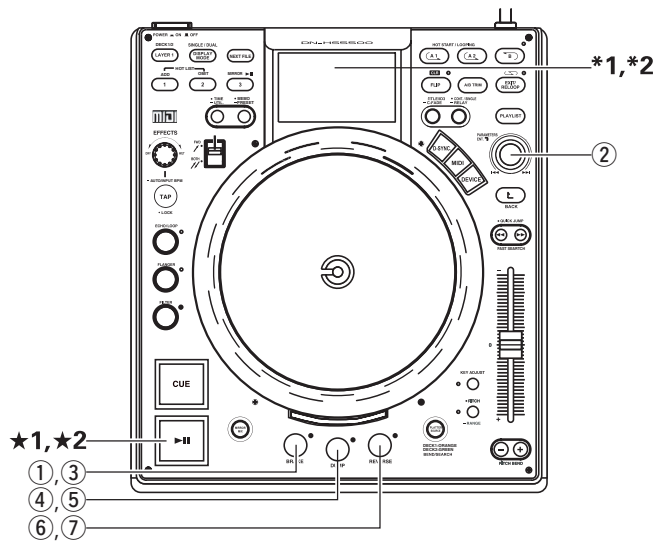

BRAKE

1-1 BRAKE
 Simulates a winding-down sound of a turntable coming to a full stop slowly.

1-1 Set the BRAKE mode
 ① The BRAKE function can be turned on by pushing the BRAKE button.

1-2 Select the BRAKE time
 When the BRAKE function is turned on, the PARAMETERS and BRAKE indicator flashes for 3 seconds and the BRAKE time is displayed. There is a 3 second "auto parameter exit mode" if no action is taken after the BRAKE button is initially pushed and after the PARAMETERS knob is adjusted.

② The BRAKE time can be selected with the PARAMETERS knob.

- When the PARAMETERS knob is pushed, the time is entered and the BRAKE time selection mode is cancelled.

*1 BRAKE time is displayed on play position indicator.

1-3 Start the BRAKE
 *1 The BRAKE is activated when the PLAY/PAUSE (▶||) button is pushed during playback.

1-4 Stop the BRAKE
 *2 The BRAKE mode can be cancelled by pressing the PLAY/PAUSE (▶||) button again during this effect.

1-5 BRAKE mode off
 ③ When the BRAKE button is pressed, the BRAKE time selection mode is set. If the BRAKE button is pressed again during this time, the BRAKE functions is turned off.

DUMP

DUMP
 Reverse playback is performed for the specified time. Plays the sound backwards while continuing in a forward motion without losing "elapsed time" when you return back to normal (forward) play.

2-1 Start the DUMP playback
 ④ The DUMP function can be turned on and Dump playback start by pushing the DUMP button during playback.

2-2 DUMP EFFECT
 • Each push of the DUMP button switches between DUMP playback and normal playback.
 • The dump play turns off when the Hot Start or stutter is started.

2-3 DUMP mode off
 ⑤ If the DUMP button is pressed when in the DUMP mode, the DUMP mode is turned off.

*Max DUMP effect time is 5 sec. After 5 sec playback will resume to normal playback.

REVERSE

3-1 Start the REVERSE playback
 ⑥ The REVERSE function can be turned on and reverse playback start by pushing the REVERSE button during playback.

3-2 REVERSE EFFECT
 • Each push of the REVERSE button switches between reverse playback and normal playback.
 *2 Play position indicator lights up in orange during reverse playback.
 • The reverse play turns off when the Hot Start or stutter is started.

3-3 REVERSE mode off
 ⑦ If the REVERSE button is pressed again during REVERSE MODE, the reverse mode is turned off.

14 2 Decks in 1

- This function enables the power of having two independent players in just one unit.
- All deck functions can be operated independently allowing for simultaneous playback and control.
- The Deck 1 playback signals are output from the LINE OUT 1 side, while Deck 2 signals are output from the LINE OUT 2 side. You will need two free channels on your mixer.
- Scratching and seamless looping is possible with the Deck2 in the same way as with the Deck1.

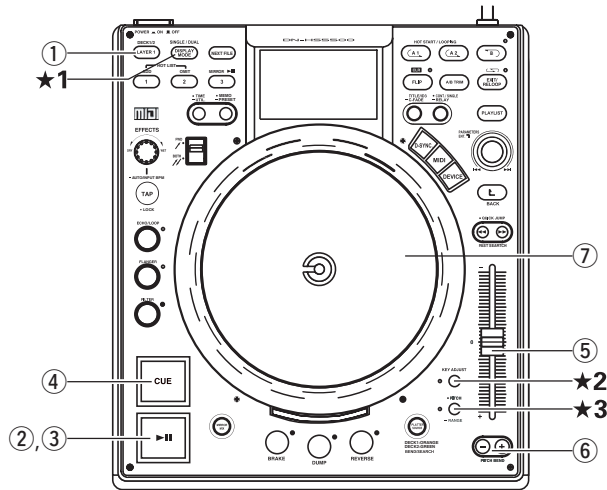

Switching the deck

When switched, the LEDs on the side of the LCD switch between Deck 1 and Deck 2.

• In the single display mode:

The main and α displays change with the display still in the single mode.

• In the dual display mode:

The display does not change.

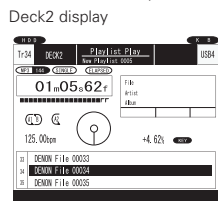
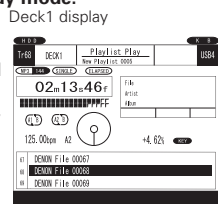

Switching the display

★1 The display switches between the single and dual modes when the DISPLAY MODE button is pressed.

- The operable track does not switch.

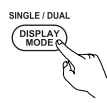

Single display mode

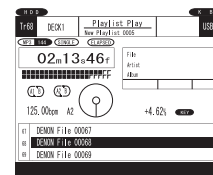

Dual display mode

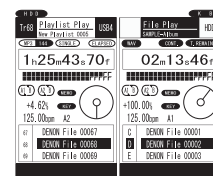

Starting playback

- 2 ② Press the PLAY/PAUSE (▶▶) button to start playback.

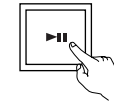

Stopping playback temporarily

- 3 ③ During playback, press the PLAY/PAUSE (▶▶) button to pause at that position. When the PLAY/PAUSE (▶▶) button is pressed again, playback resumes from the position at which it was paused.

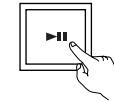

Stopping playback (back cue)

- 4 ④ When the CUE button is pressed in the pause or play mode, the standby mode is set at the α track cue point.
- Stutter playback can be performed by pressing CUE button during standby.

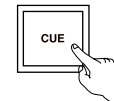

Adjusting the playing speed (pitch)

- ★2 Press the PITCH button to turn the pitch mode on.

- 5 ⑤ Move the slider to adjust the pitch.

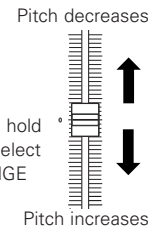

Select the pitch range

- ★3 Press the PITCH button and hold it down for 2 seconds and select the range width on the RANGE adjustment screen.

- * The pitch lock mode is set if the slider and current pitch differ when the Deck 1 and Deck 2 are switched.

Changing the playing speed (pitch) temporarily

- The playing speed can be changed temporarily using the pitch bend function.

[PITCH BEND + and - buttons]

- 6 ⑥ The playing speed increases while the PITCH BEND + button is pressed, decreases while the PITCH BEND - button is pressed.
- When the button is released, the playing speed returns to the speed set with the slider.

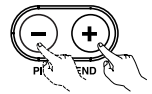

[PLATTER/SCRATCH disc]

- ⑦ The playing speed changes when the PLATTER/SCRATCH disc is turned with the platter disc mode set to "SEARCH/BEND" using the PLATTER SOURCE button.



15 MIRROR MIX

- “Mirror mix” is an effect function by which the Deck 1 and Deck 2 are played with the α track delayed by a specific amount of time (1/8, 1/4, 3/4, 1/2, 1/1 or 2/1 BPM) with respect to the main track.

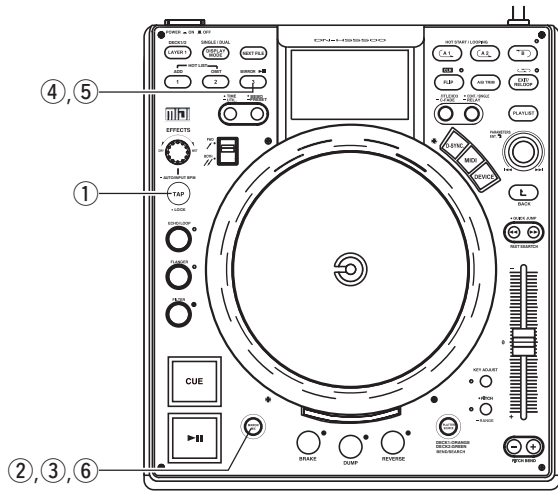

1	<p>Setting the BPM</p> <p>① Use auto BPM, TAP or BPM INPUT to set the BPM during playback of the main track.</p>
2	<p>Selecting the mirror mix mode</p> <p>② Press the MIRROR MIX button and hold it in for over 1 second to set the mirror mix mode.</p>
3	<p>Setting the mirror mix playback parameters</p> <p>③ While in the mirror mix mode. The Deck 2 delay time can now be set with the PARAMETERS knob.</p> <ul style="list-style-type: none"> • When the MIRROR MIX button is pressed again, the delay time setting mode turns off.

4	<p>Starting mirror mix playback</p> <p>④ With the Deck 1 set to Cue or Play mode, press the Function3 button to start mirror mix playback.</p>
5	<p>Stopping mirror mix playback</p> <p>⑤ During mirror mix playback, press the Function3 button to pause mirror mix playback.</p>
6	<p>Turning the mirror mix mode off</p> <p>⑥ Press the MIRROR MIX button and hold it in for over 1 second to turn the mirror mix off.</p>

16 D-SYNC FUNCTION

This function allows two independent players to be linked together by a Cross LAN cable (Within Max. 3m) that shares and controls all your connected devices from the Master device to the Remote device. Each time the D-SYNC button is pressed, Deck 2 on the set whose D-SYNC button was pressed can be controlled from the other unit.

1. Connections

Connect two units of DN-HS5500s by Cross LAN cable.

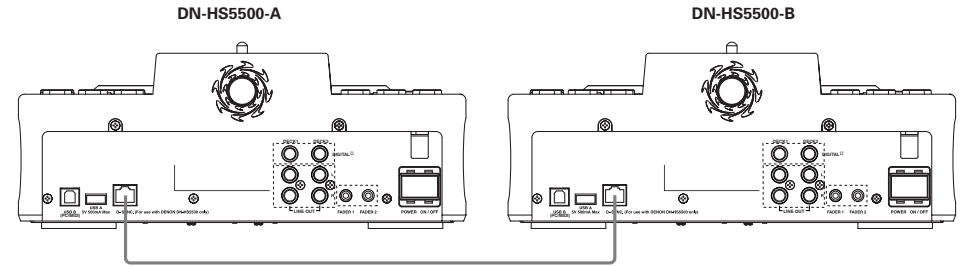

With the above connections, when the D-SYNC button on set A is pressed, set A's Deck 2 can be controlled from set B.

- The set whose D-SYNC button was pressed is called the “Master”, the other set the “Remote”.
- (In the case above, set A is the master, set B the remote.)
- The audio signals are output from the master set. They are not output from the remote set.

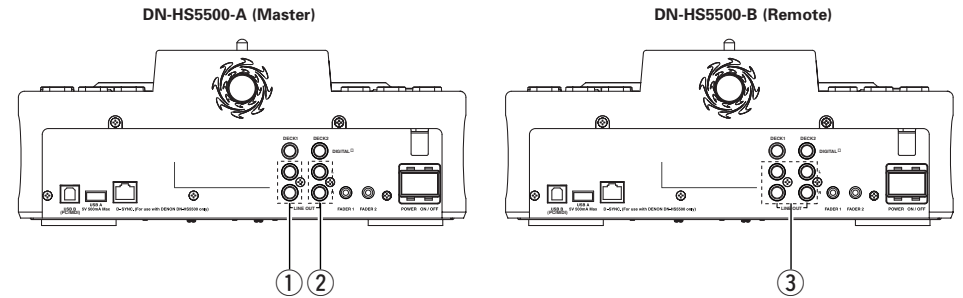

With the above connections
 The audio output (①) of Deck 1 on set A (Master) is operated from set A (Master).
 The audio output (②) of Deck 2 on set A (Master) is operated from set B (Remote).
 The audio signals (③) are not output from remote Deck 1.
 FADER 1 on the master side operates for the master side.
 FADER 2 on the master side operates for the remote side.

About USB devices
 In the D-SYNC mode, the USB device connected to the Remote side cannot be used.

2. Switching to the D-SYNC mode

- Switching to the D-SYNC mode is only possible when a deck other than Deck 1 on the master unit is set to the stop mode and operation of the master unit is set to Deck 1.
- Switching to the D-SYNC mode is not possible if the remote unit is set to the utility mode, preset mode, USB device mode, etc.

Example1: When Deck 1 on both sets A and B is being operated

Set A		Set B		D-SYNC
DECK 1	DECK 2	DECK 1	DECK 2	
Playing	Stopped	Stopped	Stopped	Switching possible
Stopped	Stopped	Stopped	Stopped	Switching possible

Example2: When set A is operating its own Deck 1 and set B is operating its own Deck 2

Set A		Set B		D-SYNC status
DECK 1	DECK 2	DECK 1	DECK 2	
Playing	Stopped	Stopped	Stopped	Switching possible
Stopped	Stopped	Stopped	Stopped	Switching possible

3. Display

The display is as shown below in the D-SYNC mode.

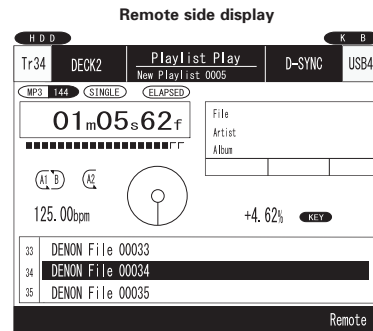
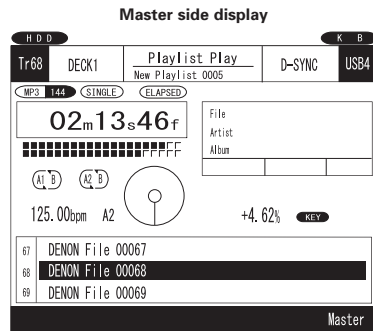

- When the D-SYNC mode is set while in the dual display mode, the display switches to the single mode.
- The dual display mode cannot be set with the DISPLAY MODE button while in the D-SYNC mode.

4. Canceling the D-SYNC mode

- With playback stopped on the remote side, press the D-SYNC button on the master or remote set to cancel the D-SYNC mode.

Example:

Master	Remote	D-SYNC status
Playing	Stopped	The D-SYNC mode is canceled.
Stopped	Stopped	The D-SYNC mode is canceled.

5. Restrictions when in the D-SYNC mode

- Switching the operated layer
When in the D-SYNC mode, the deck cannot be switched with the LAYER button for either the master or remote set.
- Device selection
It is not possible to select external devices connected to the internal HDD on the remote side.
- Utility mode
When playback is stopped on both the master and remote sets, the utility mode can be selected by pressing the TIME button on the master side and holding it down for 2 seconds.
- Preset mode
When playback is stopped on both the master and remote sets, the preset mode can be selected by pressing the MEMO button on the master side and holding it down for 2 seconds.
- Mirror mix mode
The mirror mix mode cannot be selected.
- Memo function
The memo function can be set and canceled in the same way as for normal playback.

17 MEMO (Custom Setting Memory)

The setting information can be stored in the file. The stored information can be called out of the memory at later time, making it easy to prepare for your mixing.

1. About MEMO

For the memo function, the data that can be stored in the memo differs according to the playback mode.

① For the file playback mode

- The memo data is stored in the MP3/WAV file itself, so once memo data is stored in the file, it can be called out and used when playing the file on a different DN-HS5500.
- The MEMO mode is not set in the following cases:
 - a) When the MEMO operation is being executed on the other deck.
 - b) When the database is being loaded.
 - c) When the same file is selected on both decks.

If the memo operation is possible for the deck on the side for which memo operation is set, the memo operation can be executed even when the deck on the other side is playing.

If the same track is selected for the deck on the other side, however, or if you attempt to switch to the same track, the memo operation cannot be executed.

Furthermore, if while the memo operation is being executed you attempt to search and play the track for which the memo operation is being performed on the other deck, searching is canceled and playback is stopped.

- The data stored in the memory is as follows:

- a) Cue point
- b) A1 and B1 points, A2 and B2 points
- c) Playing pitch, pitch on/off, Key Adjust on/off setting
- d) BPM data (Cue, A1 and A2 points)

The point data is limited to data within the same file.

- The MEMO indicator on the display lights up when a file for which data is storing within a file is selected.

② For the playlist playback mode

- The memo data is stored in the playlist file itself, so when transporting playlist files in which the memo data has been stored and playing them on a different DN-HS5500, that data can be called out and used.

- Memo data can be stored a total of times equal to the number of files registered in the playlist. For example, if 74 files are registered in a playlist, 74 bits of memo data can be stored in that playlist.

- The data stored in the memory is as follows:

- a) Cue point
- b) A1 and B1 points, A2 and B2 points
- c) Playing pitch, pitch on/off, Key Adjust on/off setting
- d) BPM data (Cue, A1 and A2 points)

The A1, A2, B1 and B2 points may be on different files, as long as they are within the playlist. The memo data can be used in the same way as with conventional CDs.

- The MEMO indicator on the display lights up when a file for which data is storing within a file is selected.

2. MEMO MODE SELECT

- ① Push the MEMO button during Cue mode to enter MEMO mode.

- ② Turn the PARAMETERS knob to select the various MEMO modes from as follows.

Memo Set (default), Memo Call, Memo Clr

Depending on conditions, some modes cannot be selected.

- ③ Push the MEMO button again to exit MEMO mode.

(1) Storing data in the memory [Memo Set]

- After making the settings to be storing within a file, then push CUE button.
- When the MEMO indicator in the display is off during Cue mode, push MEMO button to enable Memo set function.
- If the MEMO indicator lights up, it is necessary to clear existing Memo before storing a new Memo.
- At last push PARAMETERS knob to save. You can see "Complete!" message and the MEMO indicator lights up.
- When the Memo Set function cannot be used, check the remaining space on the device. It may not be possible to store data in the memory if there is too little space left.

(2) MEMO CALL [Memo Call]

- When a file for which a memo has been stored is called out, the MEMO indicator flashes for about 5 seconds or less.
- To call out the Memo data, select the file that you made a MEMO. Then the MEMO indicator lights up.
- Push the MEMO button to enable Memo call function.
- When the PARAMETERS knob is pushed in the Memo call mode, all the data stored in the memory is loaded. DN-HS5500 goes to standby mode at the called Cue point.
- When the playing pitch is loaded from the Memo with PITCH indicator flashes, playing Pitch is locked until Pitch Slider comes same Pitch. While playing Pitch is locked, PITCH indicator keeps flashing.

NOTE:

MEMO CALL of MP3 files may not be completed according to the file condition.

(3) MEMO CLEAR [Memo Clr]

- To clear one Memo data, select the file that you stored a MEMO. Then the MEMO indicator lights up.
- Push the MEMO button to enable Memo clear function.
- Turn the PARAMETERS knob until MEMO CLEAR is displayed.
- When the PARAMETERS knob is pushed in MEMO CLEAR mode, the Memo data is cleared and the MEMO indicator on the display turns off.

18 ABOUT CHARACTER INPUT

With the DN-HS5500, when inputting characters for playlist names, etc., the characters can be input either using the PARAMETERS knob or from a keyboard.

- Inputting using the PARAMETERS knob
Characters can be input by turning and pressing the PARAMETERS knob.
- Inputting using the keyboard
Characters can be input efficiently in the same way as when operating a computer's keyboard.
*When a keyboard is connected, it is not possible to input characters using the PARAMETERS knob.

■ Procedure for inputting using the PARAMETERS knob

• Input the character

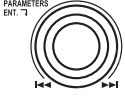
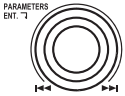
1	Select the character to input. Turn the PARAMETERS knob or scratch disc and move the cursor in the character selection section. Set the cursor to the character you want to input.	
2	Input the character. Press the PARAMETERS knob or scratch disc. The character selected in step 1 is added at the end of the character input section.	

• Enter the string of characters you have input

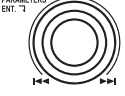
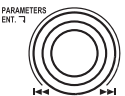
1	Select "↵". Turn the PARAMETERS knob or scratch disc and move the cursor in the character selection section. Set the cursor to "↵".	
2	Enter the string of characters you have input. Press the PARAMETERS knob or scratch disc. The string of characters in the character input section is entered and move to the next screen.	

• Clearing characters

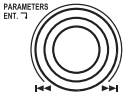
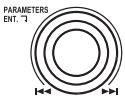
1	Select "⬅" (Back space). Turn the PARAMETERS knob or scratch disc and move the cursor in the character selection section. Set the cursor to "⬅".	
2	Clearing characters. Press the PARAMETERS knob or scratch disc. The last character in the character input section is cleared.	

■ Procedure for inputting using the keyboard

1	Input the character. When the characters are typed on the keyboard, they are added at the end of the character input section.
2	Clearing characters. Delete characters in the character input section by operating the keyboard's "BACK SPACE" keys.
3	Enter the string of characters you have input. When the keyboard's "ENTER" key is operated, the string of characters in the character input section is entered and move to the next screen.

NOTE:

- The characters usable on the DN-HS5500 are as shown on the diagram below. Note that usable characters differ according to the character input target.

	ID3 Tag (ASCII/Unicode (UTF-8/UTF-16))	File Name/Playlist Name	ID3 Tag (Genre)
Alphabet	ABCDEFGHIJKLMN OPQRSTUVWXYZ abcdefghijklmnopqrstuvwxyz	ABCDEFGHIJKLMN OPQRSTUVWXYZ abcdefghijklmnopqrstuvwxyz	ABCDEFGHIJKLMN OPQRSTUVWXYZ abcdefghijklmnopqrstuvwxyz
Numbers	0 1 2 3 4 5 6 7 8 9	0 1 2 3 4 5 6 7 8 9	0 1 2 3 4 5 6 7 8 9
Symbols	Space ! " # \$ % & ' () * + , - . / : ; < = > ? @ [\] ^ _ ` { } ~	Space ! " # \$ % & ' () + , - . ; = @ [] ^ _ ` { } ~	Space & () + _
ISO 8959-1	¡ ¢ £ ¤ ¥ ¦ § ¨ © ª « ¬ ® ¯ ° ± ² ³ ´ µ ¶ · ¸ ¹ º » ¼ ½ ¾ ¿ À Á Â Ã Ä Å Æ Ç È É Ê Ë Ì Í Î Ï Ð Ñ Ò Ó Ô Õ Ö × Ù Ú Û Ü Ý Þ ß à á â ã ä å Æ Ç È É Ê Ë Ì Í Î Ï Ð Ñ Ò Ó Ô Õ Ö × Ù Ú Û Ü Ý Þ ß à á â ã ä å Æ Ç È É Ê Ë Ì Í Î Ï Ð Ñ Ò Ó ô ÷ ø ù ú û ü ý þ ÿ	¡ ¢ £ ¤ ¥ ¦ § ¨ © ª « ¬ ® ¯ ° ± ² ³ ´ µ ¶ · ¸ ¹ º » ¼ ½ ¾ ¿ À Á Â Ã Ä Å Æ Ç È É Ê Ë Ì Í Î Ï Ð Ñ Ò Ó Ô Õ Ö × Ù Ú Û Ü Ý Þ ß à á â ã ä å Æ Ç È É Ê Ë Ì Í Î Ï Ð Ñ Ò Ó Ô Õ Ö × Ù Ú Û Ü Ý Þ ß à á â ã ä å Æ Ç È É Ê Ë Ì Í Î Ï Ð Ñ Ò Ó ô ÷ ø ù ú û ü ý þ ÿ	¡ ¢ £ ¤ ¥ ¦ § ¨ © ª « ¬ ® ¯ ° ± ² ³ ´ µ ¶ · ¸ ¹ º » ¼ ½ ¾ ¿ À Á Â Ã Ä Å Æ Ç È É Ê Ë Ì Í Î Ï Ð Ñ Ò Ó Ô Õ Ö × Ù Ú Û Ü Ý Þ ß à á â ã ä å Æ Ç È É Ê Ë Ì Í Î Ï Ð Ñ Ò Ó Ô Õ Ö × Ù Ú Û Ü Ý Þ ß à á â ã ä å Æ Ç È É Ê Ë Ì Í Î Ï Ð Ñ Ò Ó ô ÷ ø ù ú û ü ý þ ÿ

NOTE:

- You can perform any Search functions using these Latin-1 characters.
Be sure to make the region setting at "Region" in the presettings.

19 UTILITY

The DN-HS5500 offers the utilities described below.

- **File Edit**
MP3/WAV files stored on the HDD can be deleted.
Note that MP3/WAV files are deleted from the HDD when they are removed from the database, so be careful when doing so.
- **Playlist Edit**
Playlists can be edited, created and deleted.

The main functions:

- ① **Edit:** Titles can be inserted and deleted from playlists, sorted by title, etc.
 - ② **Create:** New playlists can be created.
 - ③ **Playlist Delete:** Playlists can be deleted. The MP3/WAV files are not deleted when playlists are deleted.
- **Database Edit**
A database is created on the USB HDD, etc., so that MP3/WAV files can be searched on the DN-HS5500. It is also possible to create simplified databases and to update databases.
 - **Hotlist Edit**
Deletes the tracks on the hotlist.
 - **Import/Export**
Saves the presettings along with data on a device and reads out the presettings.
Selects the Power On Play playlist.
 - **Initialization**
"Initialization" has been added to the top menu in the utility mode.
When "Initialization" is selected, "Internal HDD Format" and "Factory Default" can be selected.
 - **Diagnostic**
Measures the time required for external device file access.

NOTE: Delete list content will be deleted permanently by executing this function, be careful!

■ Setting the Utility mode

- ① When in the standby or pause mode or when no file is selected, press and hold in the UTIL. button for at least 1 second to enter the Utility mode.
 - The Utility mode cannot be set if the device selected to be operated on one of the decks is "CD".
- ② Use the PARAMETERS knob to select the utility item.
- ③ Press the UTIL. button to turn the Utility mode off.

■ File Edit

MP3/WAV files on the internal HDD can be deleted.

• Setting the File Edit mode

1

At the top menu in the Utility mode, turn the PARAMETERS knob and select "File Edit". Press the knob again to enter.

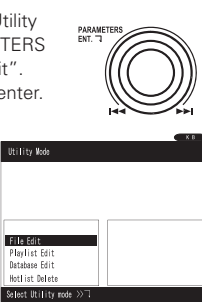

2

The "File Edit" list is displayed.



• Deleting MP3/WAV files

1

At the File Edit list, press the PARAMETERS knob to select and set "Delete".

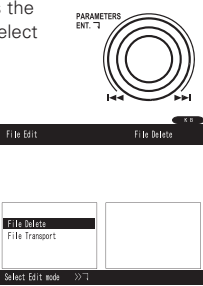

2

The File Search window is displayed at the left of the screen. Select and set the title (MP3/WAV file) you want to delete. See "Searching procedure" on page 11.

Album	SAMPLE-Album
KB DENON	85
C DENON File 00001	
D DENON File 00002	
E DENON File 00001	
F DENON File 00002	
G DENON File 00003	

3

A message asking whether you want to delete or not pops up at the bottom left of the screen.

- ① **When "OK" is selected:**
The title set in step 2 is deleted and the screen returns to as it was in step 1.
- ② **When "Exit" is selected:**
The title set in step 2 is not deleted and the screen returns to as it was in step 1.

Album	SAMPLE-Album
KB DENON	85
C DENON File 00001	
D DENON File 00002	

OK
Exit

• **Transporting MP3 and WAV files**

1 With the file edit list displayed, turn the PARAMETERS knob to select "File Transport", then press the PARAMETERS knob to set.

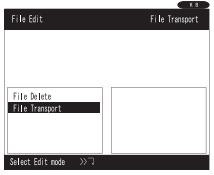

2 Select the device to which the files are to be transported.

- The currently connected devices are displayed on the left side of the screen.
- Turn the PARAMETERS knob or scratch disc to select the device for which the playlist is to be created. Press the PARAMETERS knob to set.

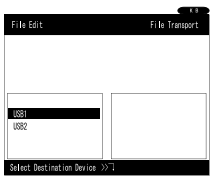

3 Select the device from which the files are to be transported.

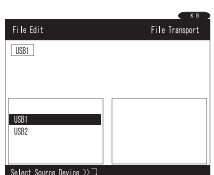

4 Select the files to be transported.

*The normal searching function can only be used if the device from which the files are to be transported has a full database. See page 11 for searching instructions.

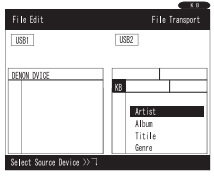

5 When a file is selected, the data is added to the list on the left. Up to 99 files can be added at once.

- When "Save&Exit" is selected: Move to step 6.
- When "Clear" is selected: The added files are cleared.

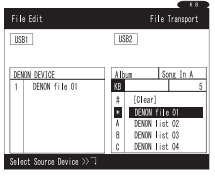

6 When "Save & Exit" is selected, a popup confirmation message appears.

- When "OK" is selected: The files selected at step 5 are transported to the device selected in step 2.
- When "Cancel" is selected: The files are not transported to the device selected in step 2. The display returns to as it was in step 5.

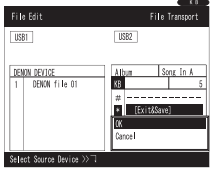

■ **Playlist Edit**

Playlists can be edited, created and deleted.

• **Setting the Playlist Edit mode**

1 At the top menu in the Utility mode, turn the PARAMETERS knob and select "Playlist Edit". Press the knob again to enter.

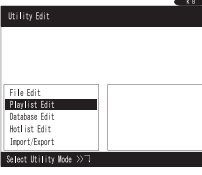

2 The "Playlist Edit" list is displayed.



• **Editing and creating playlists**

1 Editing playlists

- At the top menu in the Utility mode, turn the PARAMETERS knob and select "Edit". Press the knob again to enter.
- The unit is set to the mode for creating new playlists.

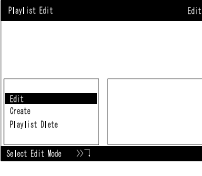

Creating playlists

- At the top menu in the Utility mode, turn the PARAMETERS knob and select "Create".
- The unit is set to the mode for creating new playlists.

2 Selecting the device

- A list of the currently connected devices (with database) is displayed on the left side of the screen.
- Turn the PARAMETERS knob and select the device for which you want to create the playlist. Press the knob again to enter. When the playlist create mode was selected, proceed to step 4.

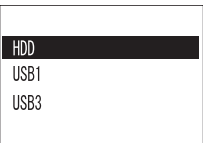

3 Creating playlists (only when "Edit" is selected)

- On the Playlist Search window at the left, select and set the playlist to be edited. See "Playlist Search" on page 12.

Category	SAMPLE
KB	DENON
C	DENON List 00001
D	DENON List 00002
E	DENON List 00003
F	DENON List 00004
G	DENON List 00005

4 Selecting the item to be edited

- A list of editing items is displayed on the left side.
- At the list, turn the PARAMETERS knob to select the item to be edited.
- After pressing the PARAMETERS knob to enter the setting, proceed to (depending on the editing item selected in ②):

- Move: Step 5
- Add: See "Playlist Create" on page 12.
- Title Delete: Step 6

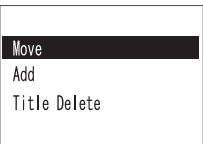

Move (changing the order of the titles)

- Note that the memo data stored for the playlist is lost when the move function is used.

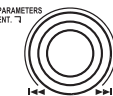

- A list of the titles registered in the playlist is displayed on the left side.
- At the list of titles, turn the PARAMETERS knob and select the title to be moved. Press the knob again to enter.
- Next, turn the PARAMETERS knob and select the position to which you want to move the title. Press the knob again to set that position. The title is moved to the selected position.
- To move other titles, repeat steps ②, ③.
- To exit the move mode, turn the PARAMETERS knob, then select and set "Exit & Save" on the list. The "Playlist Name" and "Category Name" input window appears. Input the desired characters in the respective windows as necessary then set them. See "Playlist Create" on page 12.

DENON list 0005	
1	Save & Exit
2	DENON File 00001
3	DENON File 00002
4	DENON File 00003
5	DENON File 00004
6	DENON File 00005

DENON list 0005	
KB	DENON List 0005-1

Title Delete (deleting titles)

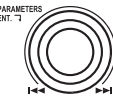

- A list of the titles registered in the playlist is displayed on the left side. The File Search window is displayed on the right.
- Turn the PARAMETERS knob and select the title you want to delete. Press the knob again to enter.
- A message asking whether you want to delete the title or not pops up at the bottom left of the screen.
 - When "OK" is selected:** The title set in step ② is deleted and the screen returns to as it was in step ①.
 - When "Cancel" is selected:** The title set in step ② is not deleted and the screen returns to as it was in step ①.
- To delete other titles, repeat steps ②, ③.
- To exit the title mode, turn the PARAMETERS knob, then select and set "Exit & Save" on the list. The "Playlist Name" and "Category Name" input window appears. Input the desired characters in the respective windows as necessary then set them. See "Playlist Create" on page 12.

DENON list 0005	
3	DENON File 00003
4	DENON File 00004
5	DENON File 00005
6	DENON File 00005
7	DENON File 00006
8	DENON File 00007

DENON list 0005	
1	Save & Exit
2	DENON File 00001
3	DENON File 00003
4	DENON File 00004
5	DENON File 00005

DENON list 0005	
1	Save & Exit
2	DENON File 00001
3	DENON File 00003
4	DENON File 00004
5	DENON File 00005

• Deleting playlists

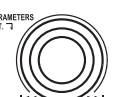

- Deleting playlists
 - At the top menu in the Utility mode, turn the PARAMETERS knob and select "Playlist Delete". Press the knob again to enter.
 - The unit is set to the mode for deleting playlists.

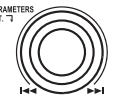

- Selecting the device
 - A list of the currently connected devices (with database) is displayed on the left side of the screen.
 - Turn the PARAMETERS knob and select the device on which the playlist you want to delete is stored. Press the knob again to enter.

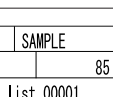

- Creating playlists
 - At the Playlist Search window at the left, select the playlist you want to delete. See "Playlist Search" on page 12.



- A message asking whether you want to delete the playlist or not pops up at the bottom left of the screen.
 - When "OK" is selected:** The playlist set in step 3 is deleted and the screen returns to as it was in step 1.
 - When "Exit" is selected:** The playlist set in step 3 is not deleted and the screen returns to as it was in step 1.

■ Database Edit

A database is created on the USB HDD, etc., so that MP3/WAV files can be searched on the DN-HS5500.

NOTE:

MP3/WAV files stored on devices other than the one for which the database is being created can be played even while the database is being creating. In this case, however, resources are required to process the file playback operation, so the time required to create the database may increase substantially. Also, when a database is created on a device, the database is reset, so any playlists created for that device are deleted.

• Setting the Database Edit mode





- At the top menu in the Utility mode, turn the PARAMETERS knob and select "Database Edit". Press the knob again to enter.

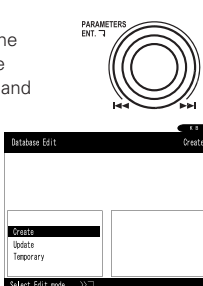
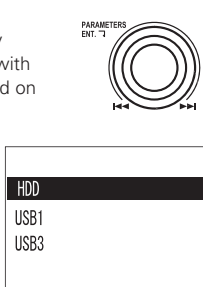

- The "Database Edit" list is displayed.

• **Creating databases**

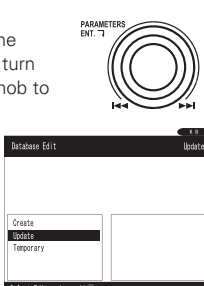
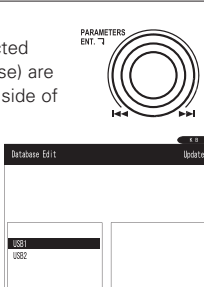
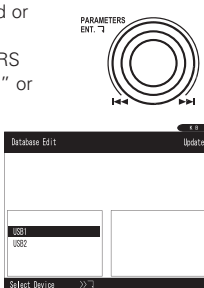

1	<p>Creating databases</p> <p>① At the top menu in the Utility mode, turn the PARAMETERS knob and select "Create".</p> <p>Press the knob again to enter.</p> <p>② The unit is set to the mode for creating databases.</p>	
2	<p>Selecting the device</p> <p>① A list of the currently connected devices (with database) is displayed on the left side of the screen.</p> <p>② Turn the PARAMETERS knob and select the device for which you want to create the database.</p> <p>Press the knob again to enter.</p> <p>NOTE: It is possible to create databases even for devices for which a database already exists. Doing so, however, creates a new database, so playlists created up to that point are deleted.</p>	
3	<p>A message asking whether you want to create the database or not pops up at the bottom left of the screen.</p> <ul style="list-style-type: none"> • When "OK" is selected: Creation of the database for the device set in step 2 starts. A progress bar is displayed, showing you the progress of the database creation operation. An indicator indicating that a database is being created is displayed even while playing MP3/WAV files. • When "Cancel" is selected: No database is created for the device set in step 2 and the screen returns to as it was in step 2. 	

• **Updating the database**

1	<p>Updating the database</p> <p>① At the top menu in the database edit mode, turn the PARAMETERS knob to select "Update".</p> <p>Press the PARAMETERS knob to set.</p> <p>② The updating mode is set.</p>	
2	<p>Selecting the device</p> <p>① The currently connected devices (with database) are displayed on the left side of the screen.</p> <p>② Turn the PARAMETERS knob to select the device whose database is to be updated.</p> <p>Press the PARAMETERS knob to set.</p> <p>*Devices cannot be selected if they have no database.</p>	
3	<p>Selecting whether to add or delete</p> <p>① Use the PARAMETERS knob to select "ADD" or "Delete".</p> <ul style="list-style-type: none"> • ADD: When there are files not registered in the database, those files are registered in the database. • Delete: Files that are registered in the database but do not actually exist are deleted from the database. • When "Cancel" is selected: The operation is ended without updating the database for the device selected in step 2. The screen in step 2 reappears. 	

• **Creating temporary databases**

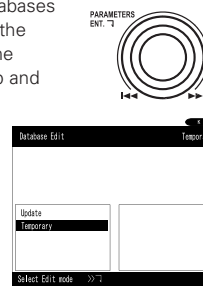
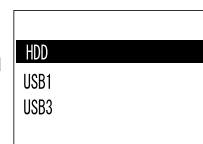
Use this procedure to create a database searchable by file name only.
This database can be created faster than a full database.
Searching using ID3 Tag data is not possible.
However, String Search is possible.

1	<p>Creating temporary databases</p> <p>① At the top menu in the Utility mode, turn the PARAMETERS knob and select "Temporary".</p> <p>Press the knob again to enter.</p> <p>② The unit is set to the mode for creating the temporary database.</p>	
2	<p>Selecting the device</p> <p>① A list of the currently connected devices is displayed on the left side of the screen.</p> <p>② Turn the PARAMETERS knob and select the device for which you want to create a temporary database.</p>	
3	<p>A message asking whether you want to create a temporary database or not pops up at the bottom left of the screen.</p> <p>① When "OK" is selected: Creation of the temporary database for the device set in step 2 starts. A progress bar is displayed, showing you the progress of the temporary database creation operation. An indicator indicating that a temporary database is being created is displayed even while playing MP3/WAV files.</p> <p>② When "Cancel" is selected: The temporary database for the device set in step 2 is not created and the screen returns to as it was in step 2.</p>	



■ **Hotlist Edit**

Use this to delete the hotlist.

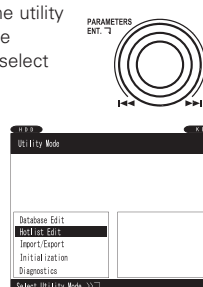
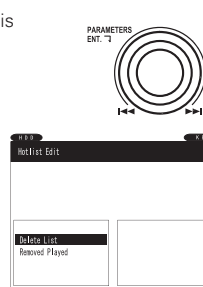

• **Hotlist Edit mode**

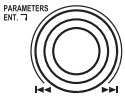
1	<p>With the top menu in the utility mode displayed, turn the PARAMETERS knob to select "Hotlist Edit".</p> <p>Press the PARAMETERS knob to set.</p>	
2	<p>The "Hotlist Edit" item is displayed.</p>	

• Delete List

1	<p>Delete List</p> <p>① With the Hotlist Edit's top menu displayed, turn the PARAMETERS knob to select "Delete List".</p> <p>② The unit is set to the Delete List mode.</p>	 
2	<p>A popup confirmation message appears.</p> <ul style="list-style-type: none"> • When "OK" is selected: The entire hotlist is deleted. A progress bar is displayed, allowing you to follow the progress. When deleting is completed, the screen in step 1 reappears. • When "Cancel" is selected: The "Delete List" operation is not performed and the screen in step 1 reappears. 	

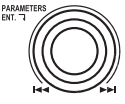

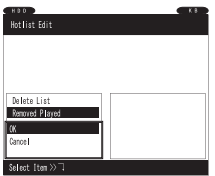
• Removed Played

1	<p>Removed Played</p> <p>① With the Hotlist Edit's top menu displayed, turn the PARAMETERS knob to select "Removed Played".</p> <p>② The unit is set to the Removed Played mode.</p>	 
2	<p>A popup confirmation message appears.</p> <ul style="list-style-type: none"> • When "OK" is selected: The files on the hotlist that have already played are deleted. A progress bar is displayed, allowing you to follow the progress. When deleting is completed, the screen in step 1 reappears. • When "Cancel" is selected: The "Removed Played" operation is not performed and the screen in step 1 reappears. 	

■ Import/Export

Use this procedure to save the presettings along with the data on a device and to read out the presettings.

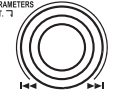
• Setting the Import/Export mode

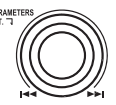
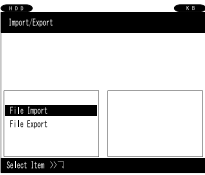
1	<p>At the top menu in the Utility mode, turn the PARAMETERS knob and select "Import/Export". Press the knob again to enter.</p>	 
2	<p>The "Import/Export" list is displayed.</p>	 

• File Import

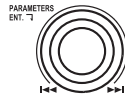
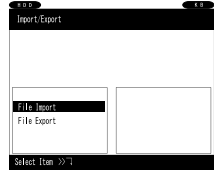
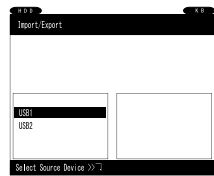
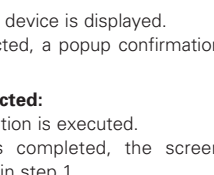
1	<p>File Import</p> <p>① At the top menu in the Import/Export, turn the PARAMETERS knob and select "Import". Press the knob again to enter.</p> <p>② The unit is set to the import mode.</p>	 
2	<p>Select the device from which the presettings are to be imported.</p>	
3	<p>A list of the data on the device is displayed. When the data is selected, a popup confirmation message appears.</p> <ul style="list-style-type: none"> • When "OK" is selected: The importing operation is executed. When importing is completed, the screen returns to as it was in step 1. • When "Cancel" is selected: The screen returns to as it was at the beginning of step 3. 	

• File Export

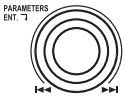
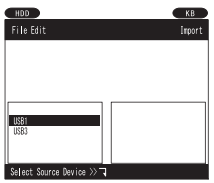
1	<p>File Export</p> <p>① At the top menu in the Import/Export, turn the PARAMETERS knob and select "Export". Press the knob again to enter.</p> <p>② The unit is set to the export mode.</p>	
2	<p>Select the device to which the presettings are to be exported.</p>	



■ Initialization

Use this procedure to format the internal HDD. Also use this function to restore the presettings for both layers to the factory defaults.

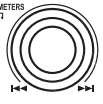
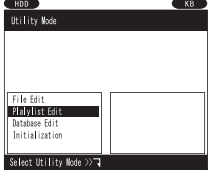
• Setting the Initialization mode

1	<p>At the top menu in the Utility mode, turn the PARAMETERS knob and select "Initialization". Press the knob again to enter.</p>	
2	<p>The "Initialization" list is displayed.</p>	

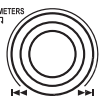
• Format (when installed)

1	<p>Format</p> <p>① At the top menu in the Initialization, turn the PARAMETERS knob and select "Format". Press the knob again to enter.</p> <p>② The unit is set to the format mode.</p> <p>*Note: This procedure will erase all contents on the Hard Drive, be careful!</p>	
		

• Factory Default

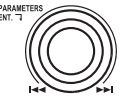
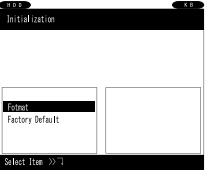
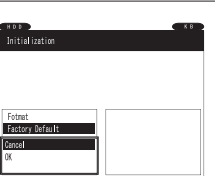
1	<p>Factory Default</p> <p>① At the top menu in the Initialization, turn the PARAMETERS knob and select "Factory Default". Press the knob again to enter.</p> <p>② The unit is set to the factory default mode.</p>	
2	<p>A popup confirmation message appears.</p> <ul style="list-style-type: none"> • When "OK" is selected: The operation for restoring the set to the factory defaults is executed. To step 3. • When "Cancel" is selected: The screen in step 1 reappears. 	
3	<p>Once the operation is executed, the end screen is displayed.</p> <ul style="list-style-type: none"> • If the operation was successful: "Complete" is displayed. • If the operation has failed: "Memory Error" is displayed. 	

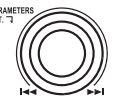
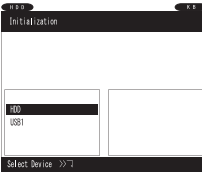
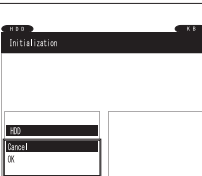
2	<p>Selecting the device</p> <p>① The currently connected devices are displayed on the left of the screen.</p> <p>② Turn the PARAMETERS knob and select the device to be formatted. Press the PARAMETERS knob to enter.</p>	
3	<p>A popup confirmation message appears at the bottom left of the screen.</p> <ul style="list-style-type: none"> • When "OK" is selected: Formatting starts. When formatting starts, a progress bar is displayed, allowing you to follow the progress. • When "Cancel" is selected: The screen in step 1 reappears. Canceling is not possible once the formatting operation starts. 	
4	<p>Once formatting is completed, a popup confirmation message asking whether you want to switch to the USB device mode appears.</p> <ul style="list-style-type: none"> • When "USB Device Mode" is selected: If connected to a computer, the set switches to the USB device mode. If not connected to a computer, a message appears. • When "Cancel" is selected: The database is created and the screen in step 2 reappears. 	

Diagnostic

This handy function verifies the USB transfer speed from each of your connected storage devices vs recommended value to ensure optimum performance and compatibility is met.

• Diagnostic mode

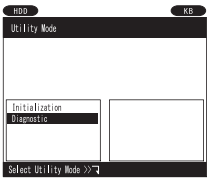
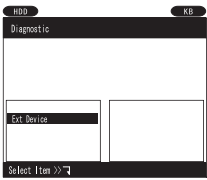
1	<p>While the top menu in the Utility Mode is displayed, turn the PARAMETERS knob to select "Diagnostic". Press the PARAMETERS knob to enter.</p>	
2	<p>The "Diagnostic" item is displayed.</p>	

• Ext Device

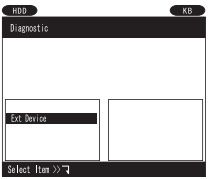
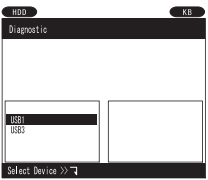
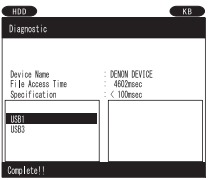
1	<p>The "Diagnostic" item is displayed. Database update ① While the top menu in the Diagnostic mode is displayed, turn the PARAMETERS knob or SCRATCH disc to select "Ext Device".</p>	
2	<p>Selecting the device ① The currently selected device is displayed on the left of the screen. ② Turn the PARAMETERS knob and select the device to be measured. Press the PARAMETERS knob to enter. *Devices cannot be selected if they have no database.</p>	
3	<p>When exited, the result for the selected device is displayed. *If device result is higher than recommended value, please discontinue usage and try another model or brand.</p>	

20 PRESET

1. Preset mode

- ① When both Decks are in the standby or pause mode, press and hold in the PRESET button for at least 1 second to enter the preset mode.
- ② Use the PARAMETERS knob to select the preset item.
- ③ Select the item and press the PARAMETERS knob to set the preset item to be changed.
- ④ Next, turn the PARAMETERS knob. The preset data is selected.
- ⑤ Select the data and press the PARAMETERS knob to set the preset data to be changed.
- ⑥ To make multiple presettings, repeat steps ② ~ ⑤.
- ⑦ The preset mode is turned off when the PRESET, CUE or PLAY/PAUSE (▶||) button is pressed.

2. Preset items and data

The "*" mark next to the data indicates the default value.

- (1) Cue Mode : DENON* (When the playback is started during the Play Pause mode, the Cue point is set.) / Other (When the Cue button is pushed during the Play Pause mode, the Cue point is set.)
- (2) Auto Cue : Auto Cue level OFF / - 60 dB / - 54 dB* / - 48 dB
- (3) Cross fade Level : OFF / - 60 dB / - 54 dB* / - 48 dB
- (4) Next File CFade : OFF / 1 sec / 2 sec / 3 sec* / 4 sec / 5 sec
Select the time for fading out the currently playing file when playback of a new file is started with the next file function.
- (5) 3/4 Effect : OFF* / ON
You can use 3/4 beat effects when you select the Echo, Flanger and Mirror Mix parameter for the effector.
- (6) Platter Speed : 33rpm* / 45rpm
Select the platter turning speed.
- (7) Jump Time : 10 sec* / 20 sec / 30 sec / 1 min
Select the jump time of Quick Jump.
- (8) Quick Jump : Time* / Beat
Select whether the jumping width when the Quick Jump function is used will be the time selected at "Jump Time" or a fixed beat.
Sets which to start up when the power is turned on.
- (9) Pitch Range : ±4 % / ±10 %* / ±16 % / ±24 %
Select the playing pitch range when the power is turned on.
- (10) EOM Time : File end warning message alert time.
(OFF / 10sec* / 15 sec / 20 sec / 30 sec / 60 sec / 90 sec)
- (11) Fader Mode (FADER START MODE) : 2L P/Cue* / 2L P/Pas / 1L P/Cue / 1L P/Pas
Select 2-line type (Play / Cue) or 2 line type (Play / Pause) or 1 line type (Play / Cue) or 1 line type (Play / Pause).
- (12) Pitch : Pitch ON* / Key AdjON (KEY ADJUST ON) / Pitch OFF
Select the pitch mode when the power is turned on.
- (13) Play Mode (SINGLE / CONTINUOUS / SINGLE PLAY LOCK) : Single / Cont. / Play Lock*
Select the play mode when the power is turned on.
- (14) Time Mode : Elapsed* / Remain
Select the time mode when the power is turned on.
- (15) TT Tricks : ON / OFF*
Select the JOG operation when you scratch in the BRAKE mode.
- (16) Audio Curve : ON* / OFF
Select "OFF" for Serato Scratch Live or other "control signal" programs.
For more information about Serato™, products please visit their website "www.scratchlive.net".

- (17) Search Step : 1step* / 2step
Select the number of steps for file searching.
- (18) Playback Mode : File* / Playlist
Select the playback mode set when the power is turned on.
- (19) File Search : Select the search mode set when the power is turned on. The preset data differs according to the playback mode.
When the playback mode is set to "File" : Artist* / Album / Title / Genre / Year / BPM / File Name / Folder
- (20) Playlist Search : Select the search mode set when the power is turned on. The preset data differs according to the playback mode.
When the playback mode is set to "Playlist" : Create* / Favorites / Top40 / Playlist Name / Category
- (21) BPM Search Range : ±0 / ±1 / ±3* / ±5 / ±10
Set the setting range for searching using the BPM search function.
- (22) Default Device : Internal / USB1* / USB2 / USB3 / USB4 / Last Device
Select the device to be used when the power is turned on.
- (23) Power On Play : ON / OFF*
Playback starts when the power is turned on.
- (24) LCD Contrast : 0 ~ 100 (default value : 40)
Set the LCD's contrast.
- (25) LCD Dimmer : High* / Mid / OFF
Select the LCD Dimmer setting.
- (26) Region : USA* / Other
Select the same region as the region set on the computer on which "DENON Music Manager" is installed.
- (27) KB Type : ENGLISH(US)* / ENGLISH(UK) / DEUTSCH / FRANCAIS / ITALIANO / ESPANOL / NEDERLANDS / SVENSKA / CHINESE / JAPANESE
Select the language type of the keyboard being used.
- (28) MIDI CH Set : 1&2* / 3&4 / 5&6
Select the MIDI channel.
- (29) Unit No Set : 1 to 14 / ALL*
Select the device's unit number.
For example, if two units of DN-HS5500s are connected to the computer, set one unit to No. 1, the other to No. 2.
- (30) Version No. : The DN-HS5500's software version is displayed. (SYSTEM / DSP)
- (31) Preset Int : Set all the preset data back to the factory defaults.
 - ① To clear the PRESET data, push the PARAMETERS knob.
"Preset Int?" flashes on the character display.
 - ② Push the PARAMETERS knob again.
"Preset Initial!" is displayed on the character display while data clearing.
 - ③ Once clearing is completed, "Complete!" is displayed.

21 COMPATIBLE FILES

NOTE:

- Depending on the type of MP3 encoding software, with some files noise may be generated or it may not be possible to play the file.
- Recordings you make are for your personal use and should not be used in ways infringing upon the copyright holder as per copyright laws.

MP3/WAV FORMAT

MP3 Format	MPEG-1	Audio Layer-3 40-320 kbps, f/s 44.1 kHz, STEREO
	ID-3 Tag	V1.0, V1.1, V2.2, V2.3, V2.4 (ASCII + ISO8859-1 (West European))
	Encoding	C.B.R, V.B.R
WAV Format	PCM	16bit f/s 44.1kHz
	Metadata Tag	Supported

NOTE: ① .m3u and .xml playlists are supported only through DENON DJ Music Manager.

22 SPECIFICATIONS

GENERAL

Type:	MP3/WAV media player and MIDI controller		
Media type:	Optional Internal HDD (2.5" PATA Type up to 120 GB) USB mass storage device (USB-HDD, USB Flash Memory)		
Dimensions:	300 (W) x 120 (H) x 334 (D) mm (without feet) 11-13/16" (W) x 4-23/32" (H) x 13-5/32" (D)		
Weight:	5.9 kg (13 lbs)		
Power supply:	U.S.A., Canada models:	AC 120 V	±10 %, 60 Hz
	European models:	AC 230 V	±10 %, 50 Hz
	Japan model	AC 100 V	±10 %, 50/60 Hz
Power consumption:	18 W		
Environmental conditions:	Operational temperature: 5 ~ 35 °C (41 ~ 95 °F) Operational humidity: 25 ~ 85 % (no condensation) Storage temperature: -20 ~ 60 °C (4 ~ 140 °F)		

AUDIO SECTION

Quantization:	16-bit linear per channel
Sampling frequency:	44.1 kHz at normal pitch
Oversampling rate:	32 times
Total harmonic distortion:	0.05 % or less (1 kHz)
Signal to noise ratio:	100 dB or more (A-weighted)
Channel separation:	100 dB or more (1 kHz)
Frequency response:	20 Hz ~ 22 kHz
Analog output	
Output level:	2.0 V r.m.s.
Load impedance:	10 kΩ or more
Digital output	
Signal format:	IEC958-Type2
Output level:	0.5 Vp-p 75 Ω

FUNCTIONS

Instant start:	Within 20 msec.
Variable pitch:	±4 % (0.02 % pitch), ±10 % (0.05 % pitch), ±16 % (0.05 % pitch) ±24 % (0.1 % pitch), ±50 % (0.5 % pitch), ±100 % (1.0 % pitch)
Pitch bend:	Pitch range ±4 % ~ ±24 % : ±32 % Pitch range ±50 %, ±100 % : -99 % ~ +100 %
Search precision:	1/75 sec. (1 subcode frame)
Max. number of files:	50,000 files/device
Max. number of Playlist:	1,000 files/device
Max. number of files per Playlist:	99/playlist
Max. number of Folders:	5,000/device
Max. number of File per Folder:	1,000/folder
Max. number of Music Title:	50,000
Max. number of Artist Name:	20,000
Max. number of Album Title:	10,000
Max. number of Music Genre:	500

* Specifications and design are subject to change without notice for purpose of improvement.

D&M Holdings Inc.
PROFESSIONAL BUSINESS COMPANY

TOKYO, JAPAN
<http://www.dm-pro.jp>

Professional Business Company, D&M Holdings Inc.
Printed in Japan 00D 511 4752 003